

# MONBAT<sup>®</sup>

## BATTERIES

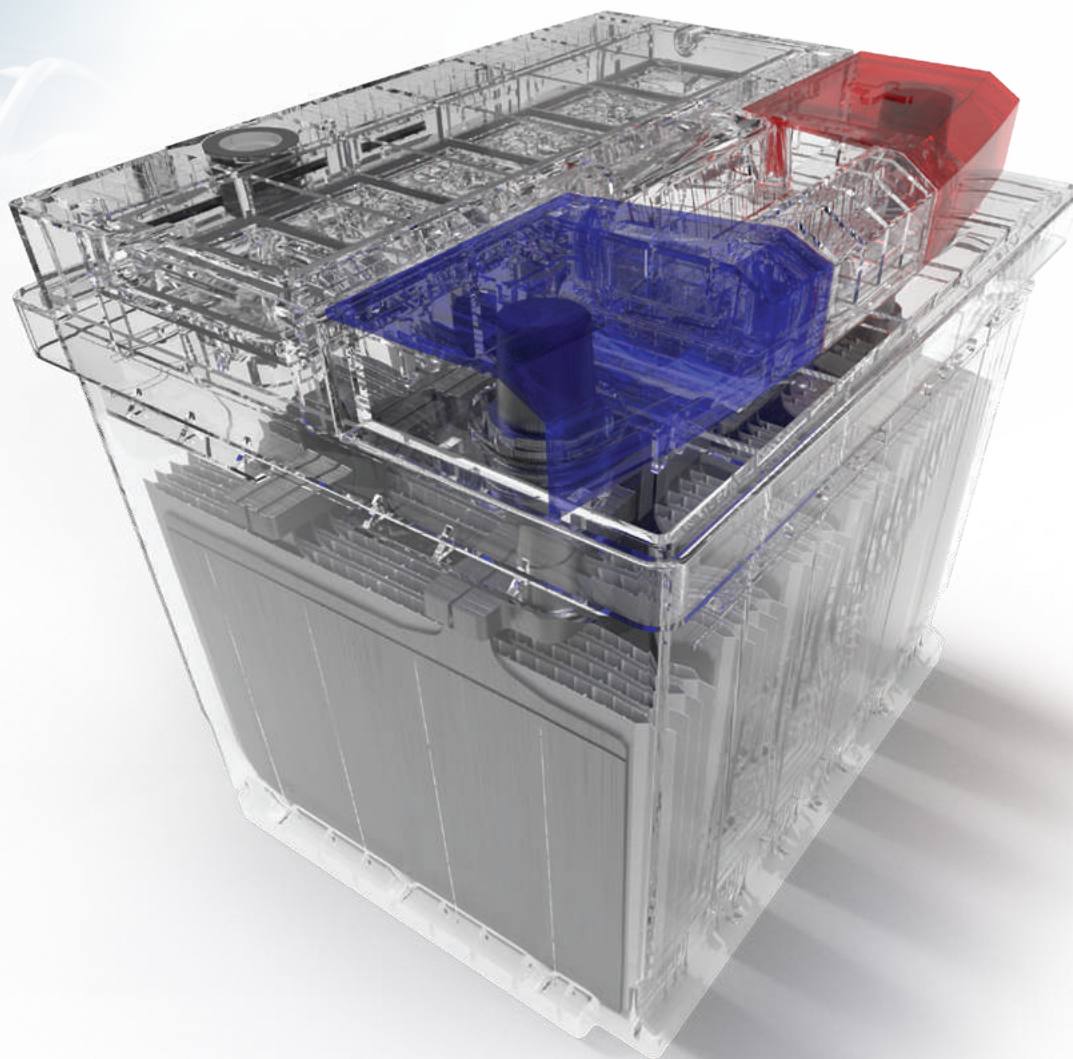

# AUTOMOTIVE CATALOGUE

LIGHT VEHICLES

COMMERCIAL AND HEAVY-DUTY VEHICLES

SPECIAL VEHICLES

# ABOUT MONBAT GROUP

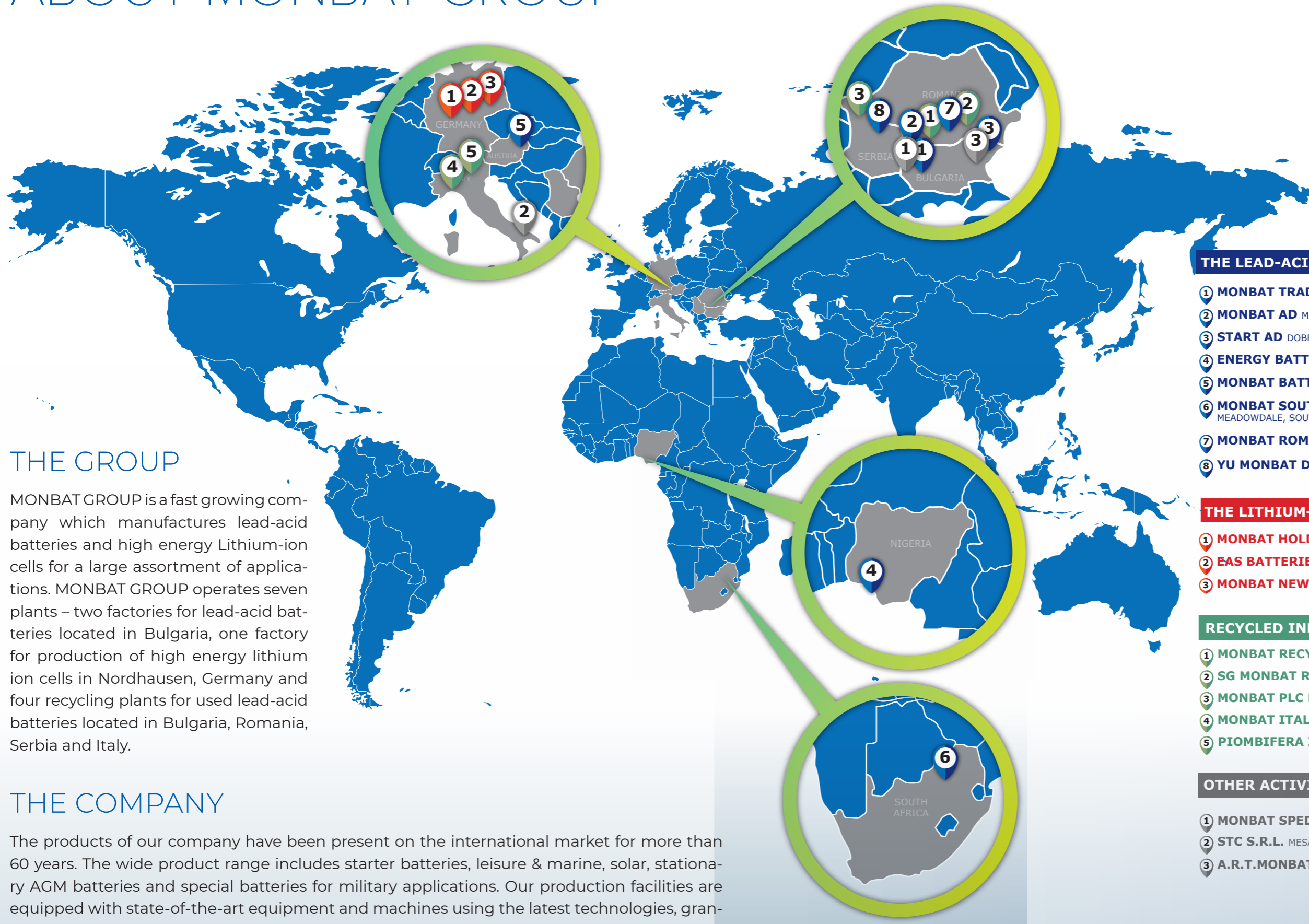

## THE GROUP

MONBAT GROUP is a fast growing company which manufactures lead-acid batteries and high energy Lithium-ion cells for a large assortment of applications. MONBAT GROUP operates seven plants – two factories for lead-acid batteries located in Bulgaria, one factory for production of high energy lithium ion cells in Nordhausen, Germany and four recycling plants for used lead-acid batteries located in Bulgaria, Romania, Serbia and Italy.

## THE COMPANY

The products of our company have been present on the international market for more than 60 years. The wide product range includes starter batteries, leisure & marine, solar, stationary AGM batteries and special batteries for military applications. Our production facilities are equipped with state-of-the-art equipment and machines using the latest technologies, granting high quality products and reaching an annual volume of over 4M batteries.

### THE LEAD-ACID BUSINESS

- 1 **MONBAT TRADING OOD** SOFIA, BULGARIA
- 2 **MONBAT AD** MONTANA, BULGARIA
- 3 **START AD** DOBRICH, BULGARIA
- 4 **ENERGY BATTERIES NIGERIA LIMITED** LAGOS, NIGERIA
- 5 **MONBAT BATTERIEN GMBH** VIENNA, AUSTRIA
- 6 **MONBAT SOUTH AFRICA PROPRIETARY LTD** MEADOWDALE, SOUTH AFRICA
- 7 **MONBAT ROMANIA SRL** BUCHAREST, ROMANIA
- 8 **YU MONBAT DOO** YAGODINA, SERBIA

### THE LITHIUM-ION BUSINESS

- 1 **MONBAT HOLDING GMBH** NORDHAUSEN, GERMANY
- 2 **EAS BATTERIES GMBH** NORDHAUSEN, GERMANY
- 3 **MONBAT NEW POWER GMBH** NORDHAUSEN, GERMANY

### RECYCLED INDUSTRIAL MATERIALS

- 1 **MONBAT RECYCLING EAD** MONTANA, BULGARIA
- 2 **SG MONBAT RECYCLING SRL** ILFOV, ROMANIA
- 3 **MONBAT PLC DOO** INDIJA, SERBIA
- 4 **MONBAT ITALY SRL** LA SPECIA, ITALY
- 5 **PIOMBIFERA ITALIANA S.P.A.** LA SPECIA, ITALY

### OTHER ACTIVITIES

- 1 **MONBAT SPED EOOD** SOFIA, BULGARIA
- 2 **STC S.R.L.** MESAGNE, ITALY
- 3 **A.R.T.MONBAT AD** DOBRICH, BULGARIA



# LIGHT VEHICLE BATTERY RANGE



## START-STOP VEHICLES

ADVANCED START-STOP	BASIC START-STOP
<b>AGM SERIES</b>	<b>EFB SERIES</b>

## CONVENTIONAL VEHICLES

HEAVY URBAN DRIVING	MODERATE EQUIPMENT	STANDARD EQUIPMENT
<b>PREMIUM SERIES</b>	<b>FORMULA SERIES</b>	<b>DYNAMIC SERIES</b>

### VEHICLE REQUIREMENTS

START-STOP SYSTEM REDUCED CO <sub>2</sub> EURO 5/6	MANUFACTURER RECOMMENDATION Change with same type				
	AGM Replace AGM	EFB Replace EFB			
START-STOP SYSTEM	✓	✓	✗	✗	✗
REGENERATIVE BRAKING	■■■■■	■■■	✗	✗	✗
HEAVY URBAN DRIVING	■■■■■	■■■■■	■■■■■	■■■	■■
ADVANCED EQUIPMENT	■■■■■	■■■■■	■■■■■	■■■	■■

### BATTERY REQUIREMENTS

CRANKING POWER - CCA	■■■■■	■■■■■	■■■■■	■■■	■■
CYCLING CAPABILITY	■■■■■	■■■■■	■■■■■	■■■	■■
CHARGE ACCEPTANCE	■■■■■	■■■■■	■■■■■	■■■	■■■
LIFE EXPECTANCY	■■■■■	■■■■■	■■■■■	■■■	■■■
<b>BEST CHOICE</b>	<b>MILD HYBRID</b>	<b>LONG LIFE</b>	<b>EXTRA POWER</b>	<b>VAST RANGE</b>	<b>CONVENTIONAL RANGE</b>

# THE FUTURE AGM START-STOP

In the coming years around 80% of newly manufactured cars will be equipped with a Start-Stop system to reduce fuel consumption and CO<sub>2</sub> emissions by turning off idling engines. Supporting Start-Stop systems is just one of the required battery functions as new cars are equipped with an increasing number of power hungry luxury features - navigation systems, multimedia displays, Wi-Fi and smartphone interfaces.



## BENEFITS

## VALVE REGULATED LEAD-ACID (VRLA)

- Original equipment (OE) quality product and specification
- Designed & developed for vehicles with advanced Start-Stop systems with regenerative braking for energy recovery
- Ensuring fuel saving and reducing CO<sub>2</sub> emissions
- 5 times better cycle life compared to conventional batteries.
- Highest cold cranking amperes (CCA) enables engine starts even in extreme climates while keeping all features functioning
- Highest Level of safety by AGM VRLA technology (Valve Regulated)
- Long shelf life
- Eco Friendly Product and 99% Recyclable

### RECOMMENDED FOR:

- Micro Hybrid & Mild Hybrid (MHEV) with Start-Stop systems
- Ideal for large cars, SUVs, vans and all modern vehicles with Start-Stop systems and power-hungry electrical items
- Wide car park coverage from limited number of SKUs
- Optimal solution for partial state of charge operation

### REMEMBER

AGM BATTERY  
MUST BE REPLACED  
WITH AGM.

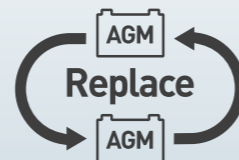

## LIGHT VEHICLE BATTERY RANGE



LEVEL M2  
EN50342-6

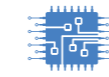

ADVANCED  
EQUIPMENT



HEAVY URBAN  
DRIVING



SAFETY OF  
OPERATION



LIFE  
EXPECTANCY



CCA  
CAPABILITY

## BATTERY CLASSIFICATION AS PER EN 50342 - 1,6:2015

Water Consumption	Charge Retention	Vibration Resistance	Endurance Level	Micro-cycle Performance
W5	C2	V3	E3	M2

## SPECIFICATIONS

Battery Type	Performance		Box	Dimensions			Technical Characteristics			
	Capacity, Ah	CCA, A [EN]		L	W	H	Layout	Terminals	Hold Down	
MD075AGM	60	640	L2	242	175	190	0		1	B13
MD096AGM	70	760	L3	278	175	190	0		1	B13
MD096LAGM	80	840	L4	310	175	190	0		1	B13
MD019AGM	95	860	L5	353	175	190	0		1	B13

- In 2019 light vehicles with Start-Stop systems accounted for nearly 36% of the European car-park mix
- The trend points to a progressive increase in the number of cars that feature a Start-Stop system in the coming years
- By 2025 the percentage of driven cars with Start-Stop systems is expected to grow to a total of 64% (Mild and Micro Hybrids)

### Expected trend for changes in the European car-park mix

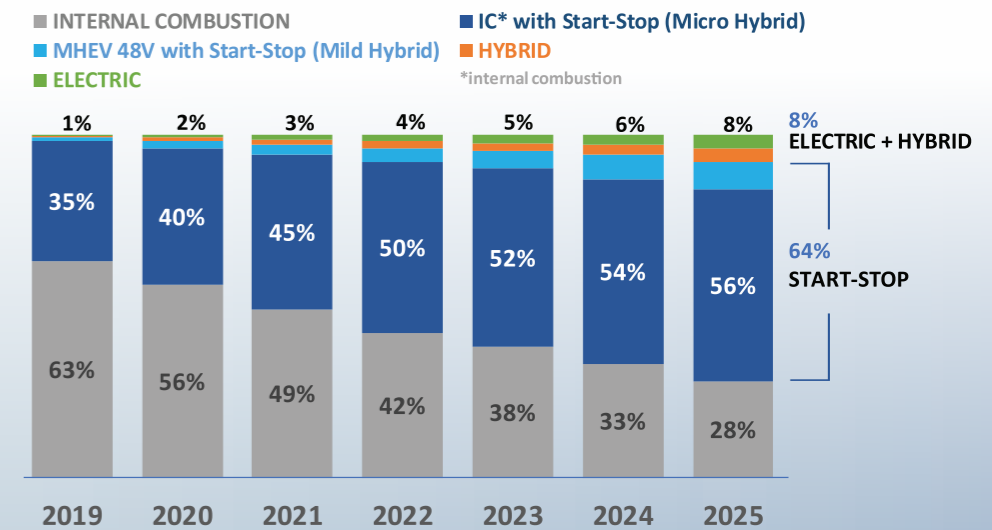

\*Source: EU28+EFTA ( European Free Trade Association ), Monbat research estimation



# NEW TREND

## EFB START-STOP

EFB technology quickly became the primary choice of most vehicle manufacturers with entry level Start-Stop systems. Vehicles today are specially designed to meet and exceed the requirements of those systems. The new extended range of MONBAT EFB series features carbon technology additives to the NAM for greater dynamic charge acceptance bringing the latest OEM trend to the aftermarket.



### BENEFITS

### SEALED MAINTENANCE FREE

- Original equipment (OE) quality product and specification
- Designed & developed for vehicles with entry level Start-Stop systems
- 4 times better cycle life compared to conventional batteries
- Exceptional dynamic charge acceptance thanks to carbon technology additive in NAM
- High level reliability for heavy urban driving on short distances and frequent stops
- Built-in charge level indicator - MAGIC EYE
- Eco Friendly Product and 99% Recyclable

### RECOMMENDED FOR:

- Micro Hybrid vehicles with entry level Start-Stop systems
- Wide car park coverage for EU and Asian models. Range features 10 types DIN and JIS sizes.
- Ideal compatibility with standard power train vehicles that make lots of regular short journeys
- Optimal solution for partial state of charge operation

### REMEMBER:

Some basic-level Start-Stop vehicles come with an EFB. EFB batteries should always be replaced with EFB. To improve performance, EFB batteries alternatively can be replaced with an AGM battery.

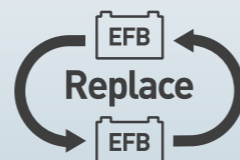

### LIGHT VEHICLE BATTERY RANGE



LEVEL M1  
EN50342-6

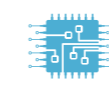

ADVANCED  
EQUIPMENT



HEAVY URBAN  
DRIVING



SEALED  
MAINTENANCE  
FREE



LIFE  
EXPECTANCY



CCA  
CAPABILITY

### BATTERY CLASSIFICATION AS PER EN 50342 - 1,6:2015

Water Consumption	Charge Retention	Vibration Resistance	Endurance Level	Micro-cycle Performance
W4	C2	V2	E2	M1

### SPECIFICATIONS

Battery Type	Performance		Box	Dimensions			Technical Characteristics			
	Capacity, Ah	CCA, A [EN]		L	W	H	Layout	Terminals	Hold Down	
EF4-075SMF	60	560	L2	242	175	190	0		1	B13
EF2-005LSMF	65	560	D23	230	170	220	0		1	B1
EF3-005RSMF	65	560	D23	230	170	220	1		1	B1
EF5-096 LOWBOXSMF	65	680	LB3	278	175	175	0		1	B13/B4
EF6-096SMF	70	680	L3	278	175	190	0		1	B13
EF9-088SMF	72	680	D26	260	170	220	0		1	B1
EF7-096L LOWBOXSMF	75	740	LB4	310	175	175	0		1	B13/B4
EF8-096LSMF	80	740	L4	310	175	190	0		1	B13
EF12-249SMF	85	740	D31	304	173	220	0		1	B1
EF10-019SMF	90	840	L5	353	175	190	0		1	B13

- In 2019 regular flooded batteries are twice as much as the Start-Stop batteries
- The trend points to a progressive increase in the number of cars that feature a Start-Stop system in the coming years
- By 2025 the percentage of driven cars with Start-Stop systems is expected to surpass flooded batteries and triple their volume.
- In addition AGM Start-Stop batteries will open a 20% gap to EFB Start-Stop due to further rise in electrical equipment

EXPECTED TREND FOR USAGE OF AGM, EFB AND REGULAR FLOODED BATTERIES

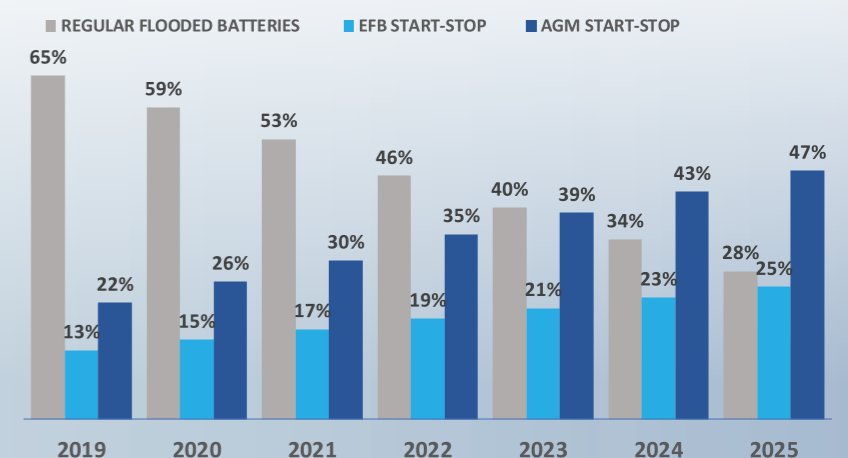

# NEXT GENERATION PREMIUM SERIES

MONBAT Premium series is the newest High Performance battery for the next generation of light vehicles with conventional ignition systems. The wide range of coverage features carbon technology additive in NAM for greater dynamic charge acceptance and brings latest OE trend to the aftermarket.



## BENEFITS

## SEALED MAINTENANCE FREE

- Original equipment (OE) quality product and specification.
- 3 times better cycle life stability compared to conventional batteries.
- Exceptional dynamic charge acceptance thanks to carbon technology additive in NAM
- Ideal for extreme weather conditions thanks to the latest Full Frame Punch technology and pasting scrim
- +30% enhanced starting power for top level performance
- High level of reliability
- Built-in charge level indicator - MAGIC EYE
- Eco Friendly Product and 99% Recyclable

### RECOMMENDED FOR:

- Designed & developed for highly equipped vehicles with the highest power demands
- Ideal compatibility with standard power train vehicles that make lots of regular short journeys in urban area
- Full coverage for all EU models of vehicles covering 90% of the car park

## LIGHT VEHICLE BATTERY RANGE

**MONBAT**  
BATTERIES



EXTREME  
TEMPERATURES

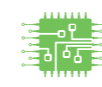

ADVANCED  
EQUIPMENT



HEAVY URBAN  
DRIVING



SEALED  
MAINTENANCE  
FREE



LIFE  
EXPECTANCY



CCA  
CAPABILITY



## BATTERY CLASSIFICATION AS PER EN 50342 - 1:2015

Water Consumption	Charge Retention	Vibration Resistance	Endurance Level
W4	C2	V2	E2

## SPECIFICATIONS

Battery Type	Performance		Box	Dimensions			Technical Characteristics			
	Capacity, Ah	CCA, A [EN]		L	W	H	Layout	Terminals	Hold Down	
MP1-054	45	330	B19	197	128	220	0		3	B0
MP1-055	45	330	B19	197	128	220	1		3	B0
MP3-056	50	350	B24	237	128	220	0		1	B0
MP3-057	50	350	B24	237	128	220	1		1	B0
MP2-063	56	560	L1	207	175	190	0		1	B13
MP4-075	66	660	L2	242	175	190	0		1	B13
MP5-005L	65	600	D23	230	170	220	0		1	B1
MP5-005R	65	600	D23	230	170	220	1		1	B1
MP6-096	80	760	L3	278	175	190	0		1	B13
MP9-088	75	630	D26	260	170	220	0		1	B1
MP11-089	75	630	D26	260	170	220	1		1	B1
MP8-096L	90	820	L4	310	175	190	0		1	B13
MP12-249	100	750	D31	304	173	220	0		1	B0
MP13-250	100	750	D31	304	173	220	1		1	B0
MP10-019	100	920	L5	353	175	190	0		1	B13



# BEST SELLER

## FORMULA ASIA SERIES

MONBAT Formula series is a vast range of automotive batteries complying with all auto car park and OE specifications. It is designed for average equipment vehicles which require extra starting power with consistently high performance for longer periods of time.



### BENEFITS

### SEALED MAINTENANCE FREE

- Original equipment (OE) quality product and specification
- Advanced Ex-Metal Calcium technology for exceptional starting power
- High level safety and longer life with built-in SMF labyrinth system for gas recombination
- Designed & developed for the complete international auto park of European and Asian models of cars
- Comprehensive range of JIS available in a HIGH HEAT Technology for Tropical Markets
- Built-in charge level indicator - MAGIC EYE
- Eco Friendly Product and 99% Recyclable

### RECOMMENDED FOR:

- Designed & developed for vehicles with average to high power demands
- Ideal compatibility with moderate power train vehicles for everyday driving
- Comprehensive Range with 58 models with 99% auto park coverage

### LIGHT VEHICLE BATTERY RANGE



### BATTERY CLASSIFICATION AS PER EN 50342 - 1:2015

Water Consumption	Charge Retention	Vibration Resistance	Endurance Level
W4	C2	V1	E1

### SPECIFICATIONS

Battery Type	Performance		Box	Dimensions			Technical Characteristics			
	Capacity, Ah	CCA, A [EN]		L	W	H	Layout	Terminals	Hold Down	
MD054	35	300	B19	197	128	220	0		3	B0
MD055	35	300	B19	197	128	220	1		3	B0
MD54H	35	300	B19	197	128	220	0		3	B1
MD056	45	330	B24	237	128	220	0		1	B0
MD057	45	330	B24	237	128	220	1		1	B0
MD005L	60	450	D23	230	170	220	0		1	B1
MD005R	60	450	D23	230	170	220	1		1	B1
MD068	60	450	D26	260	170	220	0		1	B1
MD069	60	450	D26	260	170	220	1		1	B1
MD088	70	560	D26	260	170	220	0		1	B1
MD089	70	560	D26	260	170	220	1		1	B1
MD249	95	730	D31	304	173	220	0		1	B1
MD250	95	730	D31	304	173	220	1		1	B1

# CLASSIC DYNAMIC SERIES

MONBAT Dynamic series is a classic range of automotive batteries for cars with moderate power equipment. It is a reliable solution thanks to the latest technologies that offer great value for money.



## BENEFITS

### SEALED MAINTENANCE FREE

- Original equipment (OE) quality product and specification.
- Advanced Ex-Metal Calcium technology for reliable starting power
- High level safety and longer life with built-in SMF labyrinth system for gas recombination
- The range is available upon request with standard Euro Kamina lid and reverse polarity
- Available in dry charge version
- Eco Friendly Product and 99% Recyclable

### RECOMMENDED FOR:

- Ideal compatibility with standard power train vehicles
- Comprehensive Range for wide EU car park coverage

## LIGHT VEHICLE BATTERY RANGE

**MONBAT**  
BATTERIES

  
MODERATE  
TEMPERATURES

  
STANDARD  
EQUIPMENT

  
NORMAL  
DRIVING

  
SEALED  
MAINTENANCE  
FREE







  
LIFE  
EXPECTANCY

  
CCA  
CAPABILITY

## BATTERY CLASSIFICATION AS PER EN 50342 - 1:2015

Water Consumption	Charge Retention	Vibration Resistance	Endurance Level
W3	C2	V1	E1

## SPECIFICATIONS

Battery Type	Performance		Box	Dimensions			Technical Characteristics			
	Capacity, Ah	CCA, A [EN]		L	W	H	Layout		Terminals	Hold Down
MD063	45	360	LB1	207	175	175	0		1	B13/B4
MD079	45	360	L1	207	175	190	0		1	B13
MD075	60	540	LB2	242	175	175	1		1	B13/B4
MD027	60	540	L2	242	175	190	0		1	B13
MD096	70	640	LB3	278	175	175	0		1	B13/B4
MD096L	80	720	LB4	310	175	175	0		1	B13/B4
MD019	100	840	L5	353	175	190	0		1	B13



# HEAVY-DUTY BATTERY RANGE



AGM SERIES

EFB SERIES

SMF SERIES

HD SERIES

## VEHICLE REQUIREMENTS

LIFE EXPECTANCY
EQUIPMENT LEVEL
VIBRATION RESISTENCE
CYCLING CAPABILITY
CRANKING POWER - CCA
VALUE FOR CUSTOMER

■ ■ ■ ■ ■	■ ■ ■ ■	■ ■ ■	■ ■
■ ■ ■ ■ ■	■ ■ ■ ■ ■	■ ■	■ ■
■ ■ ■ ■ ■	■ ■ ■ ■ ■	■ ■	■ ■
■ ■ ■ ■ ■	■ ■ ■ ■	■ ■	■ ■
■ ■ ■ ■ ■	■ ■ ■ ■	■ ■ ■	■ ■ ■
■ ■ ■ ■ ■	■ ■ ■ ■ ■	■ ■ ■	■ ■ ■

## RECOMMENDATION BY

APPLICATION	TYPE OF VEHICLE	
REAR END INSTALLATION		Long-haul modern trucks, Modern interstate buses
OVERNIGHT SLEEPER CAB		Long-haul modern trucks, Modern interstate buses
VIBRATION RESISTENCE		Long-haul modern trucks, Modern interstate buses
ROUGH TERRAIN		Long-haul modern trucks, Modern interstate buses, Tractors and agricultural vehicle
CYCLING CAPABILITY		Long-haul modern trucks, Modern interstate buses, Express delivery trucks, Utilities vehicles
EQUIPMENT LEVEL		Long-haul modern trucks, Modern interstate buses, Express delivery trucks, Utilities vehicles
EXTREME CLIMATE		Standart trucks with engines working at high temperatures
SPECIAL ( AGRICULTURAL AND CONSTRUCTION) VEHICLES		Tractors and agricultural vehicles, Construction machines
STANDARD VEHICLES, OLDER FLEETS		Standard and older vehicles

AGM SERIES	EFB SERIES	SMF SERIES	HD SERIES
✓	✓		
✓	✓		
✓	✓		
✓	✓		
✓	✓		
✓	✓		
	✓	✓	
	✓	✓	✓
		✓	✓

# THE FUTURE

## AGM SUPER HEAVY DUTY

MONBAT AGM SHD is the newest generation commercial vehicle battery that combines latest VRLA technology for unmatched deep cycle performance with high degree of reliability for your fleet. It has been developed in cooperation with the leading OEMs to support latest equipment innovations that will become the standard for heavy duty vehicles in the near future. AGM Super Heavy Duty is the optimal solution for unlocking the highest demanding application and power hungry features in the next generation trucks and buses.



### BENEFITS

### VALVE REGULATED LEAD-ACID (VRLA)

- Original equipment (OE) quality product and specification
- 6 times better cycle life stability compared to conventional batteries.
- Withstands deep discharges up to 80% DOD for maximum reliability.
- Highest cold cranking amperes (CCA) enables engine starts even in extreme climates while keeping hotel functions
- Maximum level of safety by AGM VRLA technology (Valve Regulated)
- Highest Vibration Resistance V3/V4
- Maintenance Free Technology with long lifespan
- Ensuring fuel saving and reducing CO2 emissions
- Eco Friendly Product and 99% Recyclable

#### RECOMMENDED FOR:

- Rear chassis installation (EURO5/6)
- Latest generation long-haul trucks with advanced hoteling function
- Latest generation city buses and coaches with highest electrical equipment
- Newest express delivery trucks with power hungry equipment or deep cycling needs
- Applications with partial state of charge operation
- Any rough terrain application under high vibrations

#### REMEMBER

AGM BATTERY MUST BE REPLACED WITH AGM.



### HEAVY-DUTY BATTERY RANGE



EXTREME EQUIPMENT	INTERNAL GAS RECOMBINATION	HIGH CYCLING DURABILITY	SPILL AND LEAK PROOF	HARD TRACK	REAR END INSTALLATION	LIFE EXPECTANCY	CCA CAPABILITY

### BATTERY CLASSIFICATION AS PER EN 50342 - 1,6:2015

Water Consumption	Charge Retention	Vibration Resistance	Endurance Level	Micro-cycle Performance
W5	C2	V3/V4	E3	M2

### SPECIFICATIONS

Battery Type	Performance		Box	Dimensions			Technical Characteristics			
	Capacity, Ah	CCA, A [EN]		L	W	H	Layout	Terminals	Hold Down	
625-AGM	220	1400	C	514	274	242	3		1	B00

### EMISSION STANDARDS AS DEFINED BY EU DIRECTIVES

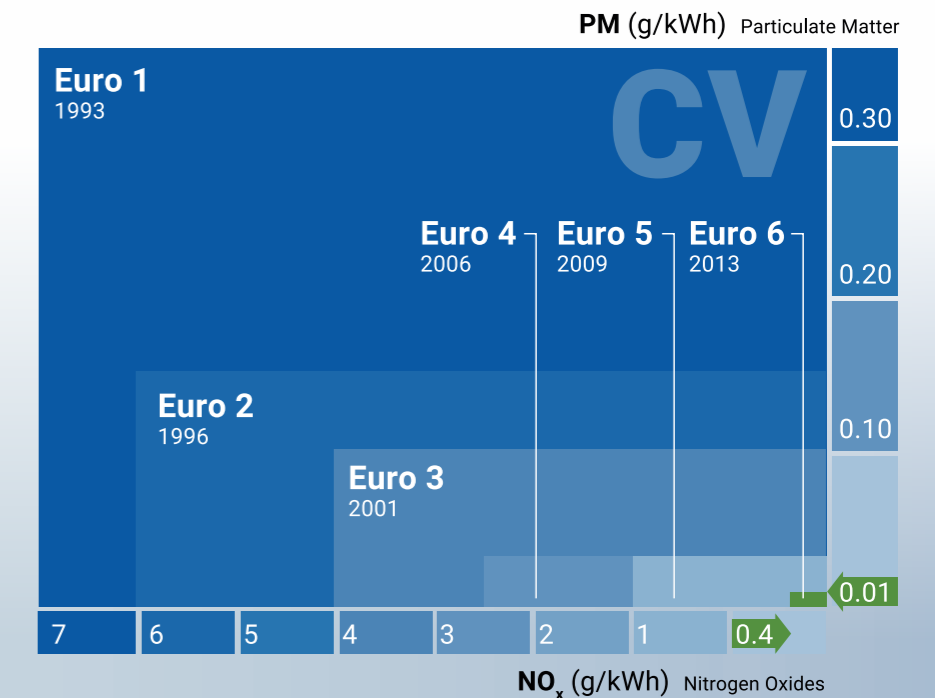

#### New EU Directives

Since 2009 EU has taken further measures regarding NOx emissions and reducing particulate matter.

Nowadays Euro 5/Euro 6 vehicles have new chassis design to integrate the Selective Catalytic Reduction (SCR) system and AdBlue tank.

Truck manufacturers have moved the batteries into the rear-chassis position and batteries are exposed to greater vibrations.



# NEW TREND

## EFB SUPER HEAVY DUTY

Today commercial vehicles are no longer simple trucks which are used as pure transport or work vehicles. Increased environmental regulations are changing the trends on the market and truck batteries today must provide not only reliable starting power but the ability to supply high power electronic equipment in EURO 5/6 vehicles. MONBAT EFB SHD range is now upgraded and enhanced to meet big energy requirements combined with high vibration resistance for absolute reliability of your fleet.



### BENEFITS

### SEALED MAINTENANCE FREE

- Original equipment (OE) quality product and specification
- 3 times the cycle life stability compared to conventional batteries
- Exceptional dynamic charge acceptance thanks to carbon technology additive in NAM
- Highest Vibration Resistance V3/V4 thanks to robust design
- High cold cranking amperes (CCA) and reliable starting after overnight stay
- High level safety and longer life with built-in SMF labyrinth system for gas recombination
- Eco Friendly Product and 99% Recyclable

### RECOMMENDED FOR:

- Rear chassis installation (EURO5/6)
- Power hungry long-haul trucks including overnight sleeper cabs
- Advanced City buses and Coaches with additional electrical equipment & consumers
- Express delivery trucks with power hungry equipment or deep cycling needs
- Applications with partial state of charge operation
- Rough terrain machines and vehicles with high vibrations
- Compatibility with any standard power train commercial vehicle with lots of regular short journeys & stops

### HEAVY-DUTY BATTERY RANGE

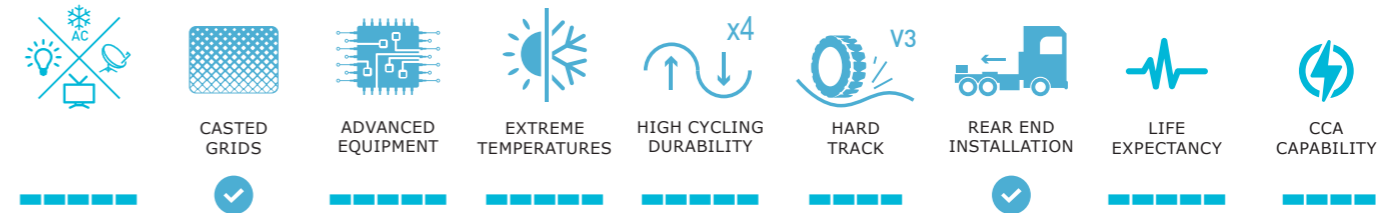

### BATTERY CLASSIFICATION AS PER EN 50342 - 1:2015

Water Consumption	Charge Retention	Vibration Resistance	Endurance Level
W4	C2	V3	E3

### SPECIFICATIONS

Battery Type	Performance		Box	Dimensions			Technical Characteristics			
	Capacity, Ah	CCA, A [EN]		L	W	H	Layout	Terminals	Hold Down	
EF14-629	185	1100	B	513	223	223	3		1	B0
EF16-625	235	1250	C	514	276	242	3		1	B0

### Fleet owners decision

Alongside the new EU Directives, several economic factors (higher fuel costs, road taxes, higher tolls, parking charges, higher charges for entering no emissions zone) have forced fleet owners to upgrade by purchasing new Euro 5/6 trucks. Installing the batteries at the rear faced the batteries under great vibrations.

Only batteries which have met V3/V4 test acc to EN 50342-6:2015 can guarantee a longer battery lifespan even in high vibration condition.

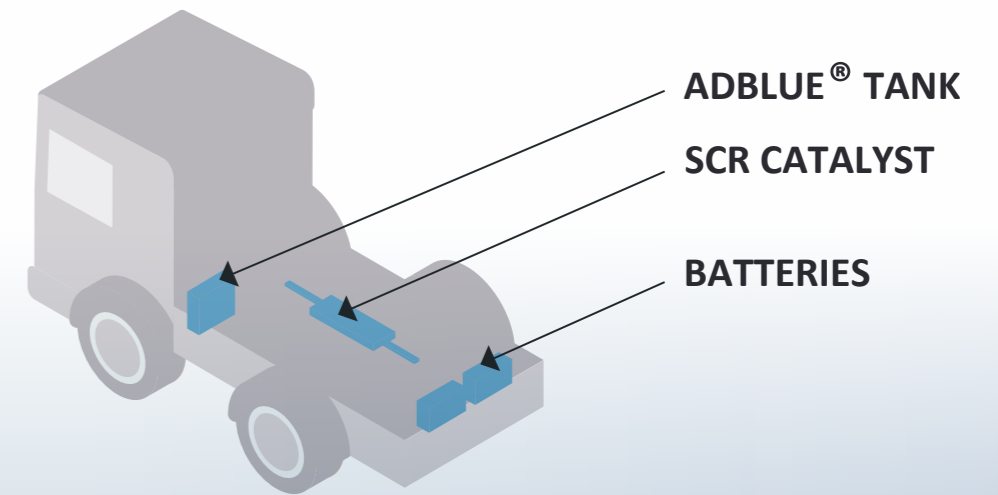

**REMEMBER**  
EFB BATTERY  
MUST BE REPLACED  
WITH EFB.



# BEST SELLER

## SMF SERIES

MONBAT SMF series is a vast range of heavy duty batteries complying with complete international CV park and any OE specifications. It is designed for standard commercial vehicles which require extra starting power with consistently high performance for longer periods of time.



### BENEFITS

### SEALED MAINTENANCE FREE

- Original equipment (OE) quality product and specification
- Advanced ConCast/ConRoll technology for for great starting power and corrosion resistance
- Highest cranking power in extreme climates
- High level safety and longer life with built-in SMF labyrinth system for gas recombination
- Wide range including special types
- Eco Friendly Product and 99% Recyclable

### RECOMMENDED FOR:

- Standard chasis installation
- Various trucks and vehicles with large engines requiring high CCA
- Agricultural and construction machines
- Ideal for standard power train commercial vehicles without special requirements in terms of vibration or cycling power

### HEAVY-DUTY BATTERY RANGE



CASTED GRIDS



MODERATE EQUIPMENT



EXTREME TEMPERATURES



LONG DISTANCE DRIVING



LIFE EXPECTANCY



CCA CAPABILITY



### BATTERY CLASSIFICATION AS PER EN 50342 - 1:2015

Water Consumption	Charge Retention	Vibration Resistance	Endurance Level
W4	C2	V2	E1

### SPECIFICATIONS

Battery Type	Performance		Box	Dimensions			Technical Characteristics			
	Capacity, Ah	CCA, A [EN]		L	W	H	Layout	Terminals	Hold Down	
31HD	120	850	GR31	336	173	235	9		1	B0
MP12-627	140	900	A	513	189	220	3		1	B0
MP14-629	180	1150	B	513	223	223	3		1	B0
MP15-623	180	1150	B	513	223	223	4		1	B0
MP16-625	230	1300	C	514	276	242	3		1	B0



# CLASSIC HEAVY DUTY

MONBAT HD series is conventional range of batteries for commercial and agricultural vehicles with basic power equipment. It is a reliable solution thanks to the latest technologies and high starting power.



## BENEFITS

### SEALED MAINTENANCE FREE

- Advanced ConCast/ConRoll technology for great starting power and corrosion resistance
- Complete range covering almost 100% of vehicle park including special types
- Available in dry charge version and reverse polarity
- Eco Friendly Product and 99% Recyclable

### RECOMMENDED FOR:

- Standard chassis installation
- Various trucks and vehicles with large engines requiring high CCA
- Agricultural and construction machines
- Continuous multi-start performance
- Ideal for standard power train commercial vehicles without special requirements in terms of vibration or cycling power

## HEAVY-DUTY BATTERY RANGE

**MONBAT**  
BATTERIES



CASTED  
GRIDS



STANDARD  
EQUIPMENT



MODERATE  
TEMPERATURES



LIFE  
EXPECTANCY



CCA  
CAPABILITY



## BATTERY CLASSIFICATION AS PER EN 50342 - 1:2015

Water Consumption	Charge Retention	Vibration Resistance	Endurance Level
W3	C2	V2	E1

## SPECIFICATIONS

Battery Type	Performance		Box	Dimensions			Technical Characteristics			
	Capacity Ah	CCA A [EN]		L	W	H	Layout	Terminals	Hold Down	
616	100	700	E41/N100	413	175	223	0		1	B0
615R	100	700	E41/N100	413	175	223	1		1	B0
MD663	110	750	Compact L	345	175	230	0		1	B0/B1
MD664	110	750	Compact L	345	175	230	1		1	B0/B1
MD655	130	840	Compact H	345	175	285	0		1	B0
MD656	130	840	Compact H	345	175	285	1		1	B0
MD627S	140	900	A	513	189	220	3		1	B0
MD629S	180	1150	B	513	223	223	3		1	B0
MD624	200	1200	C	514	276	242	4		1	B0
MD625S	230	1300	C	514	276	242	3		1	B0

# LAWN AND GARDEN

MONBAT Lawn and Garden batteries are specially designed for powering ride-on mowers, tillers and other garden machinery. From the heat of summer to the cold of winter, they deliver consistent starting power in every type of weather.



-   
**STANDARD EQUIPMENT**
-   
**MODERATE TEMPERATURES**
-   
**SEALED MAINTENANCE FREE**
-   
**LIFE EXPECTANCY**
-   
**CCA CAPABILITY**

## BENEFITS

### SEALED MAINTENANCE FREE

- Completely maintenance free, no fill-up necessary
- Enhanced safety, leakage and spill proof
- Very high cranking performance
- Increased reliability
- High endurance
- Charge level indicator
- Eco Friendly Product and 99% Recyclable



### RECOMMENDED FOR:

- Mowers and Ride-on mowers
- Tillers
- Chipper Shredders
- Snow Blowers
- Turf Vehicles

## BATTERY CLASSIFICATION AS PER EN 50342 - 1:2015

Water Consumption	Charge Retention	Vibration Resistance	Endurance Level
W4	C2	V1	E1

## SPECIFICATIONS

Battery Type	Performance		Box	Dimensions			Technical Characteristics			
	Capacity, Ah	CCA, A [EN]		L	W	H	Layout	Terminals	Hold Down	
12N24-3	28	250	U1R-9	196	128	184	0		4	B0
12N24-4	28	250	U1R-9	196	128	184	1		4	B0

## LEGEND

### Cell Assembly Layout

12 Volt

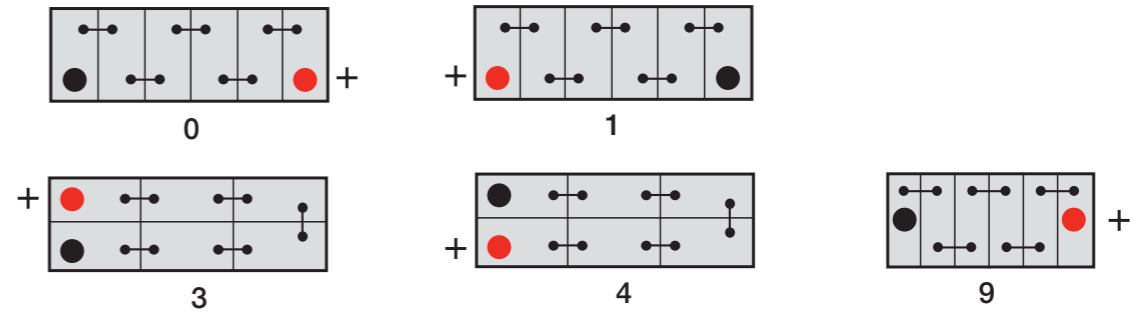

### Hold Down

B 00

without hold down

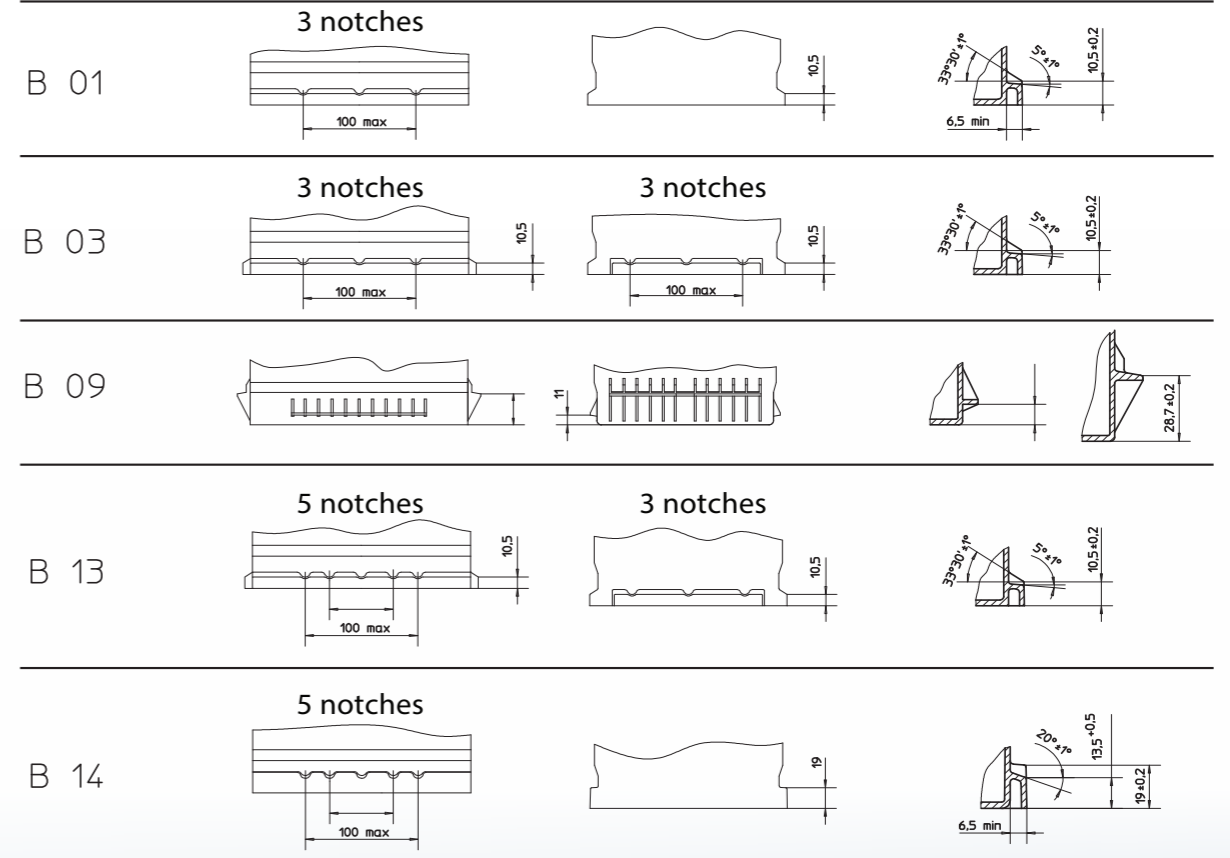

### Type of Terminals

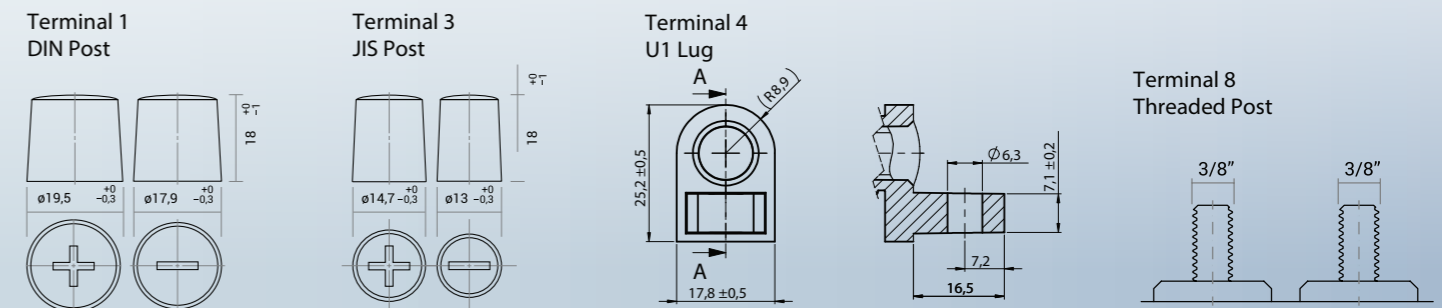





RECYCLE WITH

**MONBAT®**



Web: [www.easystartbatteries.co.uk](http://www.easystartbatteries.co.uk)

Address: Unit 9, St Marks Road, Corby,  
Northamptonshire – NN18 8AN



**THE SOURCE OF POWER**

**HEAD OFFICE**

32 A Cherni vrah blvd.

1407 Sofia, Bulgaria

tel. +359 2 962 11 50

fax: +359 2 962 11 46

e-mail: [contact@monbat.com](mailto:contact@monbat.com)

[www.monbatgroup.com](http://www.monbatgroup.com)

JANUARY 2021

ISO 9001

ISO 14001

ISO 45001

IATF 16949



**Intertek**



**Intertek**