

FRONT ACCESS AGM



HAZE

Haze Battery Company Ltd

The Haze Front Access - AGM range covers Ah capacities from 30Ah to 180Ah (C₁₀) with dimensions suitable for racking systems for maximum space utilisation. Specially designed racks and cabinets are available with cables and connectors to suit. AGM is especially suited for premium sites with low to medium outage rates and climate controlled environments, for more extreme temperature variations and increased cyclic demands please consult the Haze Front Access - GEL range. Haze facilities are fully accredited to ISO 14001 and the management system fully accredited to ISO 9001.



Features - Designed to meet the future needs of the Tele-communications industry for - mobile, wired, access, transmission, switching, integrated power applications etc. Resulting in the following benefits to the customer:

- Compactness
- ETSI / 19" / 23" Integration
- Modularity
- Rackable Standard component
- Long life
- Use under extreme conditions
- High power volume ratio
- Maintenance free utilising VRLA technology
- Low Installation costs
- Front Connections and terminal access
- Long Design Life - 12 years
- Rope handles on 100Ah upwards
- Central gassing system and hinged front covers on all models
- Integral flame arrestor
- Low Internal resistance
- Recyclable lead and plastics
- Designed to meet BELLCORE recommendations
- Low self discharge rates

Specifications

Nominal Voltage	12 Volts
Design Life	12 Years
Operating Temperature	-20 °C to 50 °C
Grid alloy	Calcium / Tin lead alloy
Plates	Flat Pasted
Separator	AGM - Absorbant Glass Mat
Active material	Very high purity lead
Case and cover	ABS (VO on request)
Charge Voltage	Float 2.27 - 2.30 VPC @20 °C Cycling 2.4 @20 °C Max. 2.45 VPC. Max ripple 0.05C (A)
Electrolyte	Sulphuric acid Analytical grade purity
Venting Valve	EPDM Rubber 1.5 to 2 psi (10.5 - 14 KPa) release pressure. Resealing at 1 psi (7 KPa)
Terminal	Epoxy sealed by extended mechanical paths
Torque setting	The recommended torque value is 5-7 Nm
Connectors	Supplied as standard (4 hr rate)



End of Discharge Voltage = 1.85								DISCHARGE CURRENT in A								20 - 25 °C				
Model	15'	20'	25'	30'	35'	40'	45'	1 hr	90'	2 hr	3 hr	4 hr	5 hr	6 hr	7 hr	8 hr	10 hr	12 hr	20 hr	24 hr
HZB12-30FA	52.5	43.6	37.2	32.8	28.9	26.0	23.5	18.5	13.2	10.5	7.66	6.17	5.14	4.41	3.88	3.44	2.83	2.41	1.51	1.29
HZB12-40FA	71.1	59.4	49.3	42.9	37.7	34.0	30.8	24.1	17.5	13.9	10.0	7.99	6.73	5.76	5.09	4.49	3.68	3.10	1.91	1.60
HZB12-55FA	99.5	80.4	67.4	59.1	52.2	47.5	43.5	34.8	25.0	20.0	14.5	11.4	9.5	8.11	7.14	6.32	5.21	4.42	2.75	2.31
HZB12-80FA	140	120	105	93.6	83.8	76.5	70.0	56.0	40.3	31.8	22.6	17.7	14.6	12.5	11.0	9.73	8.01	6.82	4.34	3.68
HZB12-95FA	159	137	120	107	96.7	88.8	81.8	65.4	47.3	37.6	27.3	21.6	17.9	15.3	13.4	11.8	9.61	8.12	5.09	4.32
HZB12-95FA-2	146	127	108	95.7	84.9	76.9	70.5	56.1	40.3	31.6	22.6	17.8	14.8	12.5	10.9	9.66	7.95	6.77	4.24	3.58
HZB12-100FA	129	118	108	100	93.2	87.8	82.5	68.7	50.2	39.5	28.1	22.1	18.3	15.5	13.6	11.9	9.78	8.28	5.16	4.35
HZB12-125FA	187	160	141	126	113	103	94.3	76.8	57.4	46.8	35.0	28.5	24.3	21.2	18.9	16.9	14.2	12.2	7.83	6.63
HZB12-150FA	200	180	166	155	144	133	123	101	73.2	57.7	41.5	32.7	27.0	23.2	20.2	17.9	14.7	12.5	7.82	6.68
HZB12-180FA	296	255	224	198	178	162	149	119	87.0	69.1	50.6	40.1	33.2	28.2	24.6	21.8	17.9	15.2	9.46	7.99

End of Discharge Voltage = 1.80								DISCHARGE CURRENT in A								20 - 25 °C				
Model	15'	20'	25'	30'	35'	40'	45'	1 hr	90'	2 hr	3 hr	4 hr	5 hr	6 hr	7 hr	8 hr	10 hr	12 hr	20 hr	24 hr
HZB12-30FA	56.1	46.5	39.7	35.1	30.9	27.8	25.1	19.7	14.1	11.2	8.18	6.59	5.49	4.71	4.15	3.68	3.02	2.57	1.61	1.37
HZB12-40FA	76.0	63.5	52.6	45.8	40.3	36.3	32.9	25.8	18.7	14.8	10.7	8.54	7.19	6.15	5.43	4.80	3.93	3.32	2.04	1.71
HZB12-55FA	106	85.8	72.0	63.1	55.8	50.7	46.5	37.1	26.7	21.4	15.5	12.2	10.1	8.67	7.63	6.75	5.56	4.72	2.94	2.47
HZB12-80FA	152	129	111	98.2	87.1	79.1	72.1	57.6	41.3	32.5	23.0	18.0	14.9	12.7	11.1	9.8	8.09	6.89	4.39	3.71
HZB12-95FA	170	147	128	115	103	94.8	87.4	69.9	50.6	40.2	29.2	23.1	19.1	16.3	14.3	12.6	10.3	8.67	5.44	4.61
HZB12-95FA-2	156	135	115	102	90.7	82.2	75.3	60.0	43.0	33.8	24.2	19.1	15.8	13.4	11.7	10.3	8.49	7.23	4.53	3.83
HZB12-100FA	138	126	115	107	100	93.8	88.1	73.4	53.6	42.2	30.0	23.6	19.5	16.6	14.5	12.8	10.4	8.84	5.51	4.65
HZB12-125FA	216	183	159	141	127	115	105	84.8	62.5	50.3	37.0	29.8	25.2	22.0	19.4	17.4	14.7	12.6	8.00	6.78
HZB12-150FA	214	193	178	165	154	142	132	108	78.2	61.6	44.3	34.9	28.8	24.8	21.6	19.1	15.7	13.3	8.35	7.14
HZB12-180FA	316	273	239	211	190	173	159	127	92.9	73.9	54.0	42.8	35.4	30.1	26.3	23.2	19.1	16.2	10.1	8.53

End of Discharge Voltage = 1.75								DISCHARGE CURRENT in A								20 - 25 °C				
Model	15'	20'	25'	30'	35'	40'	45'	1 hr	90'	2 hr	3 hr	4 hr	5 hr	6 hr	7 hr	8 hr	10 hr	12 hr	20 hr	24 hr
HZB12-30FA	59.6	49.5	42.3	37.3	32.8	29.5	26.8	21.0	15.0	12.0	8.61	6.87	5.73	4.91	4.33	3.84	3.15	2.68	1.68	1.43
HZB12-40FA	80.8	67.5	56.0	48.8	42.9	38.6	35.0	27.4	19.9	15.8	11.4	9.08	7.65	6.54	5.78	5.10	4.19	3.53	2.17	1.82
HZB12-55FA	113	91.3	76.6	67.1	59.3	53.9	49.5	39.5	28.4	22.7	16.5	13.0	10.8	9.22	8.12	7.19	5.91	5.02	3.12	2.63
HZB12-80FA	159	133	114	100	89.1	80.7	73.6	58.4	41.7	32.8	23.2	18.2	15.0	12.8	11.2	9.93	8.18	6.96	4.43	3.76
HZB12-95FA	181	156	136	122	110	101	93.0	74.3	53.8	42.8	31.0	24.6	20.4	17.3	15.2	13.4	10.9	9.23	5.79	4.91
HZB12-95FA-2	166	144	122	109	96.4	87.4	80.2	63.8	45.8	36.0	25.7	20.3	16.8	14.2	12.4	11.0	9.04	7.69	4.82	4.07
HZB12-100FA	147	134	122	114	106	99.7	93.7	78.1	57.0	44.9	31.9	25.1	20.7	17.7	15.4	13.6	11.1	9.41	5.86	4.95
HZB12-125FA	234	197	170	150	135	123	112	88.7	64.7	51.8	37.9	30.5	25.6	22.3	19.7	17.7	14.9	12.7	8.06	6.84
HZB12-150FA	227	205	189	176	163	151	140	114	83.1	65.6	47.1	37.1	30.7	26.4	23.0	20.3	16.7	14.2	8.88	7.60
HZB12-180FA	337	290	254	225	202	184	169	135	98.9	78.6	57.5	45.5	37.7	32.1	28.0	24.7	20.4	17.3	10.8	9.08

End of Discharge Voltage = 1.70								DISCHARGE CURRENT in A								20 - 25 °C				
Model	15'	20'	25'	30'	35'	40'	45'	1 hr	90'	2 hr	3 hr	4 hr	5 hr	6 hr	7 hr	8 hr	10 hr	12 hr	20 hr	24 hr
HZB12-30FA	61.0	50.6	43.2	38.1	33.6	30.2	27.3	21.5	15.3	12.2	8.89	7.16	5.97	5.12	4.51	4.00	3.28	2.80	1.75	1.49
HZB12-40FA	82.6	69.0	57.2	49.8	43.8	39.5	35.7	28.0	20.3	16.1	11.6	9.28	7.81	6.68	5.91	5.21	4.28	3.61	2.21	1.86
HZB12-55FA	116	93.3	78.2	68.6	60.6	55.1	50.6	40.4	29.1	23.2	16.8	13.3	11.0	9.42	8.29	7.34	6.04	5.13	3.19	2.68
HZB12-80FA	164	137	116	102	89.8	81.6	74.4	58.9	41.9	32.9	23.4	18.3	15.1	12.9	11.3	10.0	8.22	6.99	4.46	3.79
HZB12-95FA	185	160	139	125	112	103	95.0	76.0	55.0	43.7	31.7	25.1	20.8	17.7	15.5	13.7	11.2	9.43	5.91	5.02
HZB12-95FA-2	170	147	125	111	99	89.3	81.9	65.2	46.8	36.7	26.3	20.7	17.1	14.6	12.7	11.2	9.23	7.86	4.92	4.16
HZB12-100FA	150	137	125	116	108	102	95.8	79.8	58.3	45.9	32.6	25.6	21.2	18.1	15.8	13.9	11.4	9.62	5.99	5.06
HZB12-125FA	244	204	176	154	138	126	115	91.4	66.1	52.8	38.7	31.0	26.0	22.5	20.0	17.9	15.0	12.8	8.14	6.90
HZB12-150FA	232	210	193	180	167	155	143	117	85.0	67.0	48.2	37.9	31.3	26.9	23.5	20.8	17.1	14.5	9.08	7.76
HZB12-180FA	342	294	258	228	206	187	172	137	100	79.8	58.3	46.2	38.3	32.6	28.4	25.1	20.7	17.5	10.9	9.22

End of Discharge Voltage = 1.65										DISCHARGE CURRENT in A								20 - 25 °C			
Model	15'	20'	25'	30'	35'	40'	45'	1 hr	90'	2 hr	3 hr	4 hr	5 hr	6 hr	7 hr	8 hr	10 hr	12 hr	20 hr	24 hr	
HZB12-30FA	61.7	51.2	43.7	38.6	34.0	30.6	27.7	21.7	15.5	12.4	9.00	7.25	-	-	-	-	-	-	-	-	
HZB12-40FA	83.6	69.9	57.9	50.5	44.4	40.0	36.2	28.4	20.6	16.3	11.8	9.40	-	-	-	-	-	-	-	-	
HZB12-55FA	117	94.5	79.2	69.5	61.4	55.8	51.2	40.9	29.4	23.5	17.1	13.5	-	-	-	-	-	-	-	-	
HZB12-80FA	168	139	117	102	90.8	82.2	75.1	59.2	42.3	33.2	23.5	18.4	-	-	-	-	-	-	-	-	
HZB12-95FA	187	162	141	126	114	104	96.2	76.9	55.7	44.2	32.1	25.4	-	-	-	-	-	-	-	-	
HZB12-95FA-2	172	149	127	113	100	90.5	83.0	66.0	47.4	37.2	26.6	21.0	-	-	-	-	-	-	-	-	
HZB12-100FA	152	139	127	118	110	103	97.0	80.9	59.0	46.4	33.0	25.9	-	-	-	-	-	-	-	-	
HZB12-125FA	249	207	178	156	140	127	117	93.1	67.5	53.6	39.1	31.4	-	-	-	-	-	-	-	-	
HZB12-150FA	235	212	196	182	169	157	145	118	86.1	67.9	48.8	38.4	-	-	-	-	-	-	-	-	
HZB12-180FA	347	299	262	232	209	190	174	139	102	81.1	59.3	47.0	-	-	-	-	-	-	-	-	

End of Discharge Voltage = 1.60										DISCHARGE CURRENT in A								20 - 25 °C			
Model	15'	20'	25'	30'	35'	40'	45'	1 hr	90'	2 hr	3 hr	4 hr	5 hr	6 hr	7 hr	8 hr	10 hr	12 hr	20 hr	24 hr	
HZB12-30FA	62.3	51.7	44.2	39.0	34.3	30.9	28.0	21.9	15.7	12.5	9.09	7.32	-	-	-	-	-	-	-	-	
HZB12-40FA	84.4	70.5	58.5	51.0	44.8	40.3	36.5	28.6	20.8	16.5	11.9	9.49	-	-	-	-	-	-	-	-	
HZB12-55FA	118	95.4	80.0	70.2	62.0	56.4	51.7	41.3	29.7	23.7	17.2	13.6	-	-	-	-	-	-	-	-	
HZB12-80FA	172	141	119	103	91.6	82.7	75.5	59.6	42.5	33.3	23.6	18.4	-	-	-	-	-	-	-	-	
HZB12-95FA	189	163	142	128	115	105	97.1	77.7	56.2	44.7	32.4	25.7	-	-	-	-	-	-	-	-	
HZB12-95FA-2	173	150	128	114	101	91.3	83.8	66.7	47.9	37.6	26.9	21.2	-	-	-	-	-	-	-	-	
HZB12-100FA	153	141	128	119	111	104	98.0	81.6	59.6	46.9	33.4	26.2	-	-	-	-	-	-	-	-	
HZB12-125FA	252	209	179	157	141	128	117	94.1	68.1	54.0	39.4	31.5	-	-	-	-	-	-	-	-	
HZB12-150FA	238	214	198	184	171	158	147	120	86.9	68.5	49.2	38.8	-	-	-	-	-	-	-	-	
HZB12-180FA	350	302	264	234	211	192	176	140	103	81.7	59.8	47.3	-	-	-	-	-	-	-	-	

Front Access AGM Construction - The positive and negative grids are cast from a calcium/tin lead alloy to reduce grid growth and corrosion.

The active material is manufactured from a high purity lead (99.9999%) to minimize the impurities, which would cause corrosion and self-discharge.

The separator is mat of random woven glass fibres, they are completely acid resistant and act as a sponge soaking up and immobilizing the acid whilst keeping the acid available when it is needed during periods of battery discharge. "S Wrapping" is employed to reduce the risk of short circuit due to mossing or debris at the bottom of the cell.

The purpose of the separator is to maintain a constant distance between the positive and negative plates, totally eliminating the possibility of short circuits whilst allowing the active materials to fully react with the electrolyte. The separator also has an open construction, which offers little resistance to the flow of the electrolyte during filling.

AGM Technology - AGM technology has a number of advantages over the equivalent Gel battery range, the main advantages for the Telecommunication applications are as follows:

- Increased capacity over shorter discharge times.
- Lower initial cost.
- Ideal for starting and stationary applications.
- More suitable for UPS stand-by where power outages are uncommon.
- Smaller size battery can be used for higher rate discharges.

Haze only employ "S wrapping" in our AGM construction to further reduce the possibility of short circuits due to mossing. Closely controlled plate density and thickness results in excellent consistent performance when placed in a string (series connection) Batteries are manufactured under a quality system designed to meet and exceed ISO 9002.

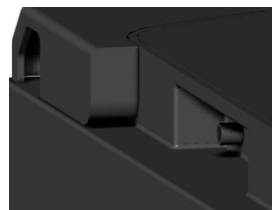

Central Gassing - Haze produce all models with an integral central gassing system. This system is a useful feature when batteries are installed in an IP66 cabinet. Sealed enclosures prevent any escaping gas from exiting, central gassing however allows a tube carrying the emissions to pass through a seal to atmosphere.

End of Discharge Voltage = 1.85										DISCHARGE IN WATTS PER CELL							20 - 25 °C			
Model	15'	20'	25'	30'	35'	40'	45'	1 hr	90'	2 hr	3 hr	4 hr	5 hr	6 hr	7 hr	8 hr	10 hr	12 hr	20 hr	24 hr
HZB12-30FA	107	88.7	76.0	66.2	58.1	52.8	48.2	38.3	27.8	22.0	15.6	12.2	10.03	8.55	7.44	6.57	5.45	4.64	2.97	2.52
HZB12-40FA	120	100	88.1	79.3	71.8	65.8	60.5	49.0	35.5	28.0	19.9	15.7	13.1	11.3	9.92	8.83	7.30	6.19	3.89	3.29
HZB12-55FA	177	156	137	123	110	99.5	90.9	72.2	52.0	40.8	28.9	22.6	18.7	16.0	14.0	12.4	10.1	8.59	5.37	4.54
HZB12-80FA	242	213	189	170	155	142	131	106	77.0	60.5	43.1	33.9	27.9	23.8	20.7	18.4	15.2	13.0	8.34	7.09
HZB12-95FA	304	259	229	205	185	170	157	125	92.6	73.6	53.0	42.3	35.5	30.5	26.9	24.0	19.8	16.8	10.3	8.68
HZB12-95FA-2	276	236	207	184	166	152	140	113	81.9	64.6	45.8	36.2	30.1	25.9	22.6	20.0	16.3	13.8	8.4	7.02
HZB12-100FA	263	239	219	205	191	178	164	131	93.6	75.0	54.3	43.0	35.9	30.7	26.8	23.7	19.4	16.3	10.0	8.43
HZB12-125FA	365	318	277	247	225	208	194	162	123	100	74.7	59.6	51.8	42.0	38.8	34.4	28.6	24.5	15.9	13.5
HZB12-150FA	391	356	334	308	290	270	251	208	149	119	85.6	67.3	55.4	47.1	40.8	36.0	29.4	24.8	15.2	12.9
HZB12-180FA	545	477	418	367	328	301	279	227	167	133	95.7	76.0	63.4	54.3	47.4	41.8	34.2	28.9	18.0	15.2

End of Discharge Voltage = 1.80										DISCHARGE IN WATTS PER CELL							20 - 25 °C			
Model	15'	20'	25'	30'	35'	40'	45'	1 hr	90'	2 hr	3 hr	4 hr	5 hr	6 hr	7 hr	8 hr	10 hr	12 hr	20 hr	24 hr
HZB12-30FA	114	94.8	81.2	70.7	62.1	56.4	51.5	40.9	29.7	23.5	16.6	13.0	10.7	9.13	7.95	7.02	5.82	4.96	3.18	2.69
HZB12-40FA	129	107	94.1	84.7	76.7	70.3	64.6	52.3	37.9	29.9	21.3	16.8	14.0	12.0	10.6	9.44	7.79	6.61	4.15	3.52
HZB12-55FA	190	166	147	131	117	106	97.1	77.1	55.5	43.6	30.8	24.1	20.0	17.0	14.9	13.2	10.8	9.18	5.73	4.85
HZB12-80FA	260	225	198	177	160	147	136	109	79.0	62.0	44.1	34.5	28.4	24.3	21.2	18.7	15.5	13.2	8.45	7.17
HZB12-95FA	325	277	245	219	197	181	167	134	99.0	78.6	56.7	45.2	37.9	32.6	28.7	25.6	21.1	17.9	11.0	9.27
HZB12-95FA-2	295	252	221	197	177	163	149	121	87.5	69.0	48.9	38.7	32.2	27.6	24.2	21.4	17.4	14.7	8.93	7.50
HZB12-100FA	281	255	234	219	204	190	175	140	100	80.1	58.0	45.9	38.3	32.8	28.7	25.3	20.7	17.4	10.7	9.00
HZB12-125FA	396	345	298	264	239	221	205	170	128	104	76.8	61.1	53.2	42.8	39.5	35.1	29.2	25.0	16.1	13.8
HZB12-150FA	418	381	357	329	310	288	269	222	160	127	91.4	71.9	59.2	50.3	43.6	38.5	31.4	26.5	16.3	13.7
HZB12-180FA	589	515	447	392	351	322	298	243	178	142	102	81.2	67.7	58.0	50.6	44.7	36.5	30.8	19.2	16.2

End of Discharge Voltage = 1.75										DISCHARGE IN WATTS PER CELL							20 - 25 °C			
Model	15'	20'	25'	30'	35'	40'	45'	1 hr	90'	2 hr	3 hr	4 hr	5 hr	6 hr	7 hr	8 hr	10 hr	12 hr	20 hr	24 hr
HZB12-30FA	121	101	86.4	75.2	66.1	60.0	54.8	43.5	31.6	25.0	17.7	13.9	11.4	9.72	8.46	7.47	6.19	5.27	3.38	2.86
HZB12-40FA	137	114	100	90.1	81.5	74.8	68.7	55.7	40.4	31.8	22.6	17.9	14.9	12.8	11.3	10.0	8.29	7.03	4.42	3.74
HZB12-55FA	202	177	156	140	125	113	103	82.0	59.1	46.4	32.8	25.7	21.2	18.1	15.9	14.1	11.5	9.77	6.10	5.16
HZB12-80FA	271	232	203	182	164	150	138	111	80.0	62.8	44.5	34.9	28.7	24.4	21.3	18.9	15.6	13.3	8.49	7.21
HZB12-95FA	346	295	260	233	210	193	178	142	105	83.6	60.3	48.1	40.3	34.6	30.6	27.2	22.5	19.0	11.8	9.86
HZB12-95FA-2	314	268	236	210	189	173	159	129	93.1	73.4	52.1	41.2	34.2	29.4	25.7	22.8	18.6	15.6	9.5	7.98
HZB12-100FA	299	271	249	233	217	202	186	149	106	85.3	61.7	48.8	40.8	34.9	30.5	26.9	22.0	18.6	11.4	9.58
HZB12-125FA	423	359	309	274	247	227	209	173	130	105	77.5	61.8	53.7	43.4	40.1	35.6	29.6	25.3	16.3	13.9
HZB12-150FA	444	405	380	350	330	307	286	236	170	135	97.3	76.5	63.0	53.5	46.4	40.9	33.4	28.2	17.3	14.6
HZB12-180FA	620	542	475	417	373	342	317	258	190	151	109	86.4	72.0	61.7	53.8	47.5	38.9	32.8	20.5	17.2

End of Discharge Voltage = 1.70										DISCHARGE IN WATTS PER CELL							20 - 25 °C			
Model	15'	20'	25'	30'	35'	40'	45'	1 hr	90'	2 hr	3 hr	4 hr	5 hr	6 hr	7 hr	8 hr	10 hr	12 hr	20 hr	24 hr
HZB12-30FA	124	103	88.3	76.9	67.5	61.3	56.0	44.5	32.3	25.6	18.1	14.2	11.7	9.93	8.64	7.63	6.33	5.39	3.45	2.92
HZB12-40FA	140	116	102	92.1	83.3	76.4	70.2	56.9	41.2	32.5	23.1	18.2	15.2	13.1	11.5	10.3	8.47	7.19	4.51	3.82
HZB12-55FA	206	181	159	143	127	116	106	83.8	60.4	47.4	33.5	26.2	21.7	18.5	16.2	14.4	11.8	9.98	6.24	5.28
HZB12-80FA	278	236	206	184	166	151	139	112	80.7	63.4	44.8	35.1	28.9	24.6	21.5	19.0	15.7	13.4	8.55	7.28
HZB12-95FA	353	301	266	238	214	197	182	146	108	85.5	61.6	49.2	41.2	35.4	31.2	27.8	23.0	19.5	12.0	10.08
HZB12-95FA-2	320	274	241	214	193	177	162	131	95.1	75.0	53.2	42.1	35.0	30.0	26.3	23.3	19.0	16.0	9.71	8.15
HZB12-100FA	305	277	255	238	222	206	190	152	109	87.1	63.0	49.9	41.7	35.7	31.2	27.5	22.5	19.0	11.6	9.79
HZB12-125FA	435	365	314	277	250	228	211	175	131	106	78.1	62.3	54.1	43.6	40.4	35.8	29.8	25.5	16.4	13.9
HZB12-150FA	454	414	388	358	337	314	292	241	173	138	99.4	78.2	64.4	54.7	47.4	41.8	34.2	28.8	17.7	14.9
HZB12-180FA	633	554	486	426	381	350	324	264	194	155	111	88.3	73.6	63.0	55.0	48.6	39.7	33.5	20.9	17.6

End of Discharge Voltage = 1.65										DISCHARGE IN WATTS PER CELL								20 - 25 °C			
Model	15'	20'	25'	30'	35'	40'	45'	1 hr	90'	2 hr	3 hr	4 hr	5 hr	6 hr	7 hr	8 hr	10 hr	12 hr	20 hr	24 hr	
HZB12-30FA	126	104	89.4	77.8	68.4	62.1	56.7	45.0	32.7	25.9	18.3	14.4	-	-	-	-	-	-	-	-	
HZB12-40FA	142	118	104	93.3	84.4	77.4	71.1	57.6	41.8	32.9	23.4	18.5	-	-	-	-	-	-	-	-	
HZB12-55FA	209	183	161	145	129	117	107	84.9	61.1	48.0	34.0	26.6	-	-	-	-	-	-	-	-	
HZB12-80FA	284	240	209	186	167	153	140	113	81.4	63.8	45.2	35.3	-	-	-	-	-	-	-	-	
HZB12-95FA	358	305	269	241	217	200	184	147	109	86.5	62.4	49.8	-	-	-	-	-	-	-	-	
HZB12-95FA-2	325	278	244	217	195	179	164	133	96.3	76.0	53.9	42.6	-	-	-	-	-	-	-	-	
HZB12-100FA	309	281	258	241	225	209	193	154	110	88.2	63.8	50.5	-	-	-	-	-	-	-	-	
HZB12-125FA	443	368	316	279	251	230	213	176	131	106	78.1	62.6	-	-	-	-	-	-	-	-	
HZB12-150FA	460	419	393	362	341	318	296	244	176	140	101	79.2	-	-	-	-	-	-	-	-	
HZB12-180FA	641	561	492	431	386	354	328	267	196	157	113	89.4	-	-	-	-	-	-	-	-	

End of Discharge Voltage = 1.60										DISCHARGE IN WATTS PER CELL								20 - 25 °C			
Model	15'	20'	25'	30'	35'	40'	45'	1 hr	90'	2 hr	3 hr	4 hr	5 hr	6 hr	7 hr	8 hr	10 hr	12 hr	20 hr	24 hr	
HZB12-30FA	127	105	90.3	78.6	69.0	62.7	57.3	45.5	33.0	26.1	18.5	14.5	-	-	-	-	-	-	-	-	
HZB12-40FA	143	119	105	94.2	85.2	78.2	71.8	58.2	42.2	33.2	23.7	18.7	-	-	-	-	-	-	-	-	
HZB12-55FA	211	185	163	146	130	118	108	85.7	61.7	48.5	34.3	26.8	-	-	-	-	-	-	-	-	
HZB12-80FA	289	242	210	187	169	154	141	114	81.8	64.0	45.4	35.5	-	-	-	-	-	-	-	-	
HZB12-95FA	361	308	272	244	219	202	186	149	110	87.4	63.0	50.3	-	-	-	-	-	-	-	-	
HZB12-95FA-2	328	280	246	219	197	181	166	134	97.3	76.7	54.4	43.0	-	-	-	-	-	-	-	-	
HZB12-100FA	312	284	260	243	227	211	194	155	111	89.1	64.4	51.0	-	-	-	-	-	-	-	-	
HZB12-125FA	448	369	317	280	252	232	214	177	132	106	78.5	63.0	-	-	-	-	-	-	-	-	
HZB12-150FA	464	423	397	366	345	321	299	246	177	141	102	79.9	-	-	-	-	-	-	-	-	
HZB12-180FA	648	566	497	435	390	358	331	270	198	158	114	90.2	-	-	-	-	-	-	-	-	

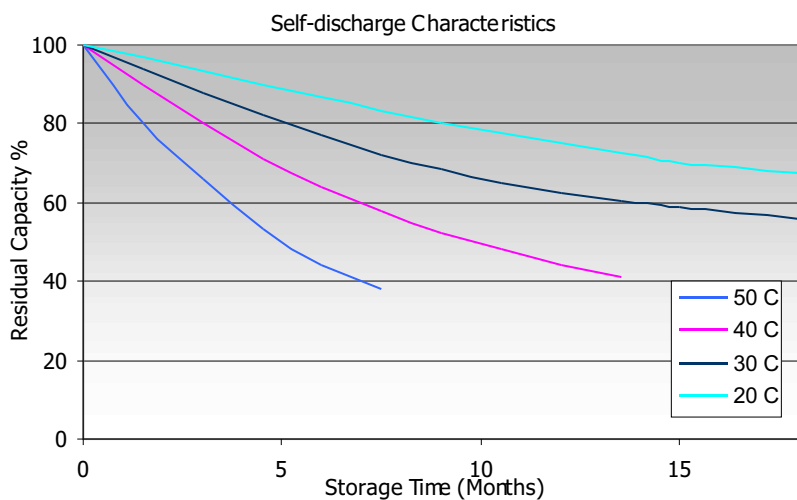

Applications

- Float service
- Uninterruptible Power Supplies
- Medical
- Telecommunications
- Switch Gear
- Photovoltaic
- Solar
- Wind
- Control Systems
- Cellular Radio Stations
- Cathodic Protection
- Navigation Aids
- Marine equipment
- Electric Power Systems

End of Discharge Voltage = 1.85									DISCHARGE CAPACITY Ah								20 - 25 °C			
Model	15'	20'	25'	30'	35'	40'	45'	1 hr	90'	2 hr	3 hr	4 hr	5 hr	6 hr	7 hr	8 hr	10 hr	12 hr	20 hr	24 hr
HZB12-30FA	13.1	14.5	15.7	16.4	16.9	17.3	17.7	18.5	19.8	21.0	23.0	24.7	25.7	26.5	27.2	27.7	28.3	28.9	30.2	30.9
HZB12-40FA	17.8	19.8	20.8	21.5	22.1	22.6	23.1	24.1	26.2	27.7	30.0	32.0	33.6	34.6	35.6	36.1	36.8	37.3	38.1	38.4
HZB12-55FA	24.9	26.8	28.4	29.5	30.6	31.6	32.7	34.8	37.5	40.0	43.5	45.8	47.3	48.8	50.0	50.8	52.1	53.0	55.0	55.4
HZB12-80FA	35.0	40.1	43.7	46.8	49.1	51.0	52.5	56.0	60.5	63.6	67.8	70.6	73.1	75.0	76.8	78.2	80.1	81.8	86.9	88.2
HZB12-95FA	39.7	45.8	50.5	53.7	56.7	59.2	61.3	65.4	71.0	75.2	81.9	86.5	89.5	91.9	93.5	94.6	96.1	97.4	102	104
HZB12-95FA-2	36.5	42.2	45.4	47.9	49.7	51.3	52.9	56.1	60.4	63.3	67.9	71.4	73.8	75.5	76.5	77.6	79.5	81.2	84.8	86.0
HZB12-100FA	32.3	39.3	44.9	50.0	54.6	58.5	61.9	68.7	75.3	79.0	84.3	88.2	91.3	93.3	94.9	96.0	97.8	99.4	103	105
HZB12-125FA	47.7	54.5	59.8	64.3	67.2	69.8	72.2	78.3	87.9	95.4	107	116	124	130	135	139	145	150	160	162
HZB12-150FA	50.0	60.2	69.3	77.4	84.3	88.7	92.6	101	110	115	124	131	135	139	142	144	147	150	156	160
HZB12-180FA	74.1	85.1	93.1	98.9	104	108	112	119	131	138	152	160	166	169	172	175	179	183	189	192

End of Discharge Voltage = 1.80									DISCHARGE CAPACITY Ah								20 - 25 °C			
Model	15'	20'	25'	30'	35'	40'	45'	1 hr	90'	2 hr	3 hr	4 hr	5 hr	6 hr	7 hr	8 hr	10 hr	12 hr	20 hr	24 hr
HZB12-30FA	14.0	15.5	16.8	17.5	18.1	18.5	18.9	19.7	21.2	22.5	24.5	26.3	27.5	28.3	29.0	29.6	30.2	30.9	32.3	33.0
HZB12-40FA	19.0	21.2	22.2	22.9	23.6	24.2	24.6	25.8	28.0	29.6	32.1	34.1	35.9	37.0	38.0	38.6	39.3	39.8	40.7	41.1
HZB12-55FA	26.6	28.6	30.4	31.6	32.7	33.8	34.9	37.1	40.1	42.7	46.5	48.9	50.5	52.2	53.4	54.3	55.6	56.7	58.7	59.2
HZB12-80FA	38.1	42.9	46.3	49.1	51.0	52.7	54.1	57.6	61.9	64.9	69.0	71.8	74.3	76.3	77.9	79.1	80.9	82.7	87.8	89.0
HZB12-95FA	42.4	48.9	53.9	57.4	60.5	63.2	65.5	69.9	75.9	80.4	87.5	92.4	95.7	98.1	99.8	101	103	104	109	111
HZB12-95FA-2	39.0	45.1	48.5	51.1	53.1	54.8	56.5	60.0	64.6	67.6	72.5	76.3	78.9	80.6	81.7	82.9	84.9	86.8	90.6	91.9
HZB12-100FA	34.5	42.0	47.9	53.4	58.3	62.5	66.1	73.4	80.4	84.4	90.0	94.2	97.5	99.7	101	103	104	106	110	112
HZB12-125FA	55.1	62.1	67.5	71.8	75.8	78.4	80.7	86.6	95.6	103	113	122	129	135	139	143	150	154	163	166
HZB12-150FA	53.4	64.3	74.0	82.7	90.0	94.8	98.9	108	117	123	133	140	144	149	151	154	157	160	167	171
HZB12-180FA	79.1	90.9	99.5	106	111	116	119	127	139	148	162	171	177	181	184	187	191	195	202	205

End of Discharge Voltage = 1.75									DISCHARGE CAPACITY Ah								20 - 25 °C			
Model	15'	20'	25'	30'	35'	40'	45'	1 hr	90'	2 hr	3 hr	4 hr	5 hr	6 hr	7 hr	8 hr	10 hr	12 hr	20 hr	24 hr
HZB12-30FA	14.9	16.5	17.8	18.7	19.2	19.7	20.1	21.0	22.5	23.9	25.8	27.5	28.6	29.6	30.3	30.8	31.5	32.2	33.7	34.4
HZB12-40FA	20.2	22.5	23.6	24.4	25.1	25.7	26.2	27.4	29.8	31.5	34.1	36.3	38.2	39.4	40.5	41.0	41.9	42.3	43.3	43.7
HZB12-55FA	28.3	30.4	32.3	33.6	34.8	35.9	37.1	39.5	42.6	45.4	49.5	52.0	53.8	55.5	56.8	57.8	59.1	60.3	62.5	63.0
HZB12-80FA	39.8	44.4	47.6	50.2	52.2	53.8	55.2	58.4	62.6	65.5	69.7	72.6	75.0	77.0	78.6	79.9	81.8	83.5	88.6	90.2
HZB12-95FA	45.2	52.0	57.4	61.1	64.4	67.3	69.7	74.3	80.7	85.5	93.1	98.3	102	104	106	108	109	111	116	118
HZB12-95FA-2	41.5	47.9	51.6	54.4	56.5	58.3	60.1	63.8	68.7	71.9	77.2	81.1	83.9	85.7	86.9	88.2	90.4	92.3	96.3	97.7
HZB12-100FA	36.7	44.6	51.0	56.8	62.0	66.5	70.3	78.1	85.6	89.7	95.8	100	104	106	108	109	111	113	117	119
HZB12-125FA	59.8	67.0	72.3	76.4	80.1	83.5	85.7	90.5	99.1	106	116	124	131	137	141	145	152	156	165	168
HZB12-150FA	56.8	68.4	78.8	88.0	95.8	101	105	114	125	131	141	149	153	158	161	163	167	170	178	182
HZB12-180FA	84.2	96.7	106	112	118	123	127	135	148	157	172	182	189	192	196	199	204	207	215	218

End of Discharge Voltage = 1.70									DISCHARGE CAPACITY Ah								20 - 25 °C			
Model	15'	20'	25'	30'	35'	40'	45'	1 hr	90'	2 hr	3 hr	4 hr	5 hr	6 hr	7 hr	8 hr	10 hr	12 hr	20 hr	24 hr
HZB12-30FA	15.2	16.9	18.2	19.1	19.7	20.1	20.5	21.5	23.0	24.4	26.7	28.6	29.9	30.8	31.6	32.1	32.8	33.5	35.1	35.8
HZB12-40FA	20.6	23.0	24.1	24.9	25.7	26.3	26.8	28.0	30.4	32.2	34.9	37.1	39.1	40.2	41.4	41.9	42.8	43.3	44.3	44.7
HZB12-55FA	28.9	31.1	33.0	34.3	35.5	36.7	37.9	40.4	43.6	46.4	50.5	53.1	54.9	56.7	58.1	59.0	60.4	61.6	63.9	64.4
HZB12-80FA	41.1	45.5	48.3	50.8	52.6	54.4	55.8	58.9	62.9	65.8	70.1	73.1	75.4	77.5	79.0	80.2	82.2	83.9	89.1	90.9
HZB12-95FA	46.2	53.2	58.7	62.4	65.8	68.7	71.2	76.0	82.5	87.4	95.2	100	104	107	109	110	112	113	118	120
HZB12-95FA-2	42.4	49.0	52.8	55.6	57.8	59.6	61.4	65.2	70.2	73.5	78.9	82.9	85.7	87.6	88.9	90.2	92.3	94.3	98	100
HZB12-100FA	37.5	45.6	52.1	58.1	63.4	68.0	71.9	79.8	87.4	91.7	97.9	102	106	108	110	111	114	115	120	121
HZB12-125FA	62.3	69.4	74.7	78.7	82.3	85.6	88.1	93.3	101	108	119	127	132	138	143	147	153	157	166	169
HZB12-150FA	58.1	69.9	80.5	89.9	97.9	103	107	117	127	134	144	152	157	162	164	167	171	174	182	186
HZB12-180FA	85.4	98.2	107	114	120	125	129	137	151	160	175	185	191	195	199	202	207	211	218	221

End of Discharge Voltage = 1.65										DISCHARGE CAPACITY Ah								20 - 25 °C			
Model	15'	20'	25'	30'	35'	40'	45'	1 hr	90'	2 hr	3 hr	4 hr	5 hr	6 hr	7 hr	8 hr	10 hr	12 hr	20 hr	24 hr	
HZB12-30FA	15.4	17.1	18.5	19.3	19.9	20.4	20.8	21.7	23.3	24.8	27.0	29.0	-	-	-	-	-	-	-	-	
HZB12-40FA	20.9	23.3	24.4	25.2	26.0	26.6	27.1	28.4	30.8	32.6	35.3	37.6	-	-	-	-	-	-	-	-	
HZB12-55FA	29.3	31.5	33.4	34.7	36.0	37.2	38.4	40.9	44.1	47.0	51.2	53.8	-	-	-	-	-	-	-	-	
HZB12-80FA	41.9	46.3	48.9	51.2	53.2	54.8	56.3	59.2	63.4	66.3	70.4	73.4	-	-	-	-	-	-	-	-	
HZB12-95FA	46.7	53.8	59.4	63.2	66.7	69.6	72.2	76.9	83.5	88.5	96.4	102	-	-	-	-	-	-	-	-	
HZB12-95FA-2	42.9	49.6	53.4	56.3	58.5	60.3	62.2	66.0	71.1	74.4	79.9	84.0	-	-	-	-	-	-	-	-	
HZB12-100FA	37.9	46.2	52.8	58.8	64.2	68.8	72.8	80.9	88.6	92.9	99.1	104	-	-	-	-	-	-	-	-	
HZB12-125FA	63.4	70.5	75.6	79.6	83.2	86.4	89.3	95.0	103	109	120	128	-	-	-	-	-	-	-	-	
HZB12-150FA	58.8	70.7	81.5	91.1	99.1	104	109	118	129	136	146	154	-	-	-	-	-	-	-	-	
HZB12-180FA	86.8	100	109	116	122	127	131	139	153	162	178	188	-	-	-	-	-	-	-	-	

End of Discharge Voltage = 1.60										DISCHARGE CAPACITY Ah								20 - 25 °C			
Model	15'	20'	25'	30'	35'	40'	45'	1 hr	90'	2 hr	3 hr	4 hr	5 hr	6 hr	7 hr	8 hr	10 hr	12 hr	20 hr	24 hr	
HZB12-30FA	15.6	17.2	18.6	19.5	20.1	20.6	21.0	21.9	23.5	25.0	27.3	29.3	-	-	-	-	-	-	-	-	
HZB12-40FA	21.1	23.5	24.7	25.5	26.3	26.9	27.4	28.6	31.1	32.9	35.7	38.0	-	-	-	-	-	-	-	-	
HZB12-55FA	29.5	31.8	33.8	35.1	36.3	37.6	38.8	41.3	44.6	47.5	51.7	54.3	-	-	-	-	-	-	-	-	
HZB12-80FA	42.9	47.0	49.6	51.7	53.7	55.1	56.6	59.6	63.8	66.6	70.7	73.8	-	-	-	-	-	-	-	-	
HZB12-95FA	47.2	54.4	60.0	63.8	67.3	70.3	72.9	77.7	84.3	89.3	97.3	103	-	-	-	-	-	-	-	-	
HZB12-95FA-2	43.4	50.1	54.0	56.8	59.1	60.9	62.8	66.7	71.8	75.2	80.6	84.8	-	-	-	-	-	-	-	-	
HZB12-100FA	38.3	46.6	53.3	59.4	64.8	69.5	73.5	81.6	89.4	93.8	100	105	-	-	-	-	-	-	-	-	
HZB12-125FA	64.3	71.1	76.2	80.2	83.7	86.9	89.8	96.0	104	110	121	129	-	-	-	-	-	-	-	-	
HZB12-150FA	59.4	71.4	82.3	91.9	100	105	110	120	130	137	148	155	-	-	-	-	-	-	-	-	
HZB12-180FA	87.5	101	110	117	123	128	132	140	154	163	179	189	-	-	-	-	-	-	-	-	

GAS RECOMBINATION - The gasses generated during normal operation of the battery are internally recombined. In fact more than 99% of the gas achieves recombination.

SAFETY RELEASE VALVE- The battery will operate above atmospheric pressure under normal operating conditions, however the maximum pressure is governed by the safety release valve. Open is activated by pressures in excess of approx. 2 psi (14 Kpa), resealing at approx 1.2 psi (8.4 Kpa).

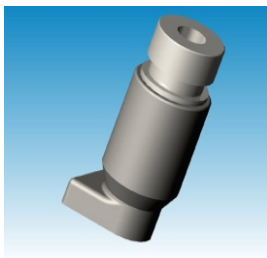

TERMINAL CONSTRUCTION - The contact quality between the insert terminal and the lead post is of vital importance during short duration / high Amp discharges. Elevated terminal temperatures are the result of poor contact, eventually causing seal degradation and electrolyte leaks. Haze design and assembly technique for terminal casting ensures trouble free operation for the design life of the battery.



Capacity temperature correction Factor to be applied to Data at 20 Degrees C												
Discharge Time	-30 °C	-20 °C	-10 °C	0 °C	5 °C	10 °C	15 °C	20-25 °C	30 °C	35 °C	40 °C	50 °C
5 minutes to 59 minutes	24%	36%	45%	68%	77%	83%	92%	100%	105%	107%	108%	110%
1 Hour to 100 Hours	28%	41%	58%	73%	79%	86%	94%	100%	104%	106%	107%	108%

Battery Model	Qty Per Box	Dimensions (mm) & approx weight (kg)				Dimensions (Inches) & approx weight (Lbs)				Terminal Layout	Internal Resistance mOhms	Maximum Charge Current
		Length	Width	Height	Weight	Length	Width	Height	Weight			
HZB12-30FA	1	225	99	225	10.1	8.86	3.90	8.86	22.3	M5	5	7.5
HZB12-40FA	1	225	99	225	13.1	8.86	3.90	8.86	29.0	M5	5	10
HZB12-55FA	1	277	105	223	17.9	10.91	4.13	8.78	39.6	M6	4.3	15
HZB12-80FA	1	563	114	182	26.8	22.17	4.49	7.17	59.2	M6	3.6	20
HZB12-95FA	1	507	109	227	32.5	19.96	4.29	8.94	71.8	M6	4.1	25
HZB12-95FA-2	1	395	105	257	27.5	15.55	4.13	10.12	60.8	M6	3.8	25
HZB12-100FA	1	395	110	285	32.6	15.55	4.33	11.22	72.0	M6	3.6	30
HZB12-125FA	1	417	172	240	46.0	16.42	6.77	9.45	101.7	M6	2.9	35
HZB12-150FA	1	550	109	286	48.5	21.65	4.29	11.26	107.2	M6	3.1	40
HZB12-180FA	1	560	125	320	57.9	22.05	4.92	12.60	128.0	M8	2.9	45

The graph shows extrapolated Design Life condition for Haze batteries at different ambient temperatures. Clearly higher ambient temperatures will reduce service life.

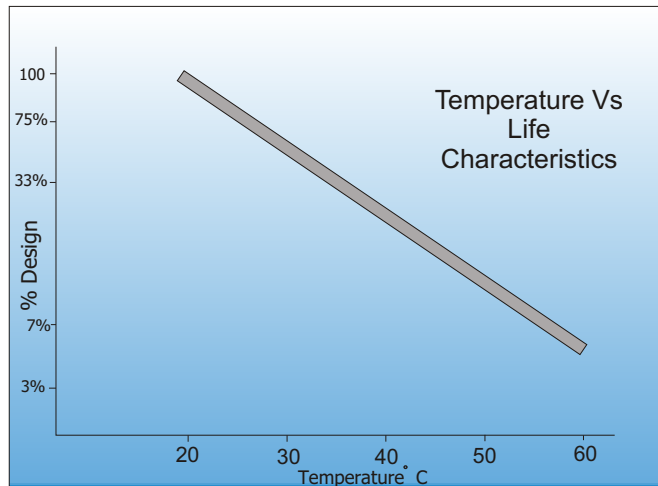

Temperature	Shelf Life
0 °C - 20 °C (32 °F - 68 °F)	12 Months
21 °C - 30 °C (69 °F - 86 °F)	9 Months
31 °C - 40 °C (87 °F - 104 °F)	5 Months
41 °C - 50 °C (105 °F - 112 °F)	2.5 Months

Operating Temperature	Recommended Applied Float Voltage VPC
0-9	2.33 - 2.35
10-14	2.30 - 2.33
15-19	2.27 - 2.30
20-24	2.27 - 2.30
25-29	2.25 - 2.27
30-34	2.23 - 2.25
35-40	2.21 - 2.23

CHARGING CHARACTERISTICS

Floating - The optimum float voltage for a battery is temperature dependant, at 15 - 24°C the recommended value is 2.27 - 2.30V. It is recommended that battery installation sites are temperature controlled, however float voltage can be increased or decreased to compensate for temperature variations. Adjustment is calculated at +/- 3 mV per degree C.

The most suitable charging method for battery life and performance is the constant voltage method with a limited initial current, usually limited to a maximum of $C_{20}/4$.

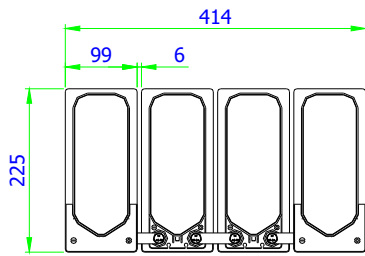

12-30&40 Front Access
Battery Height: 225mm

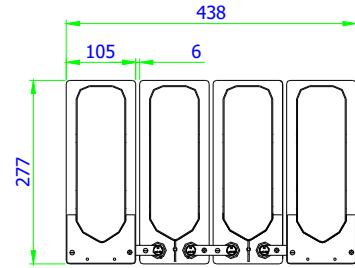

12-50&55 Front Access
Battery Height: 223mm

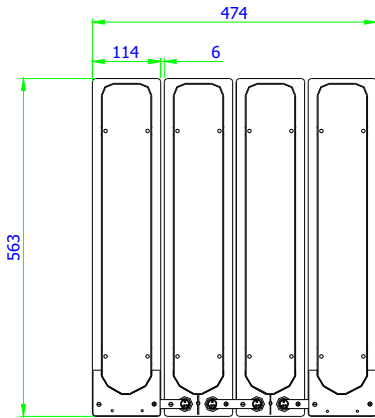

12-70&80 Front Access
Battery Height: 182mm

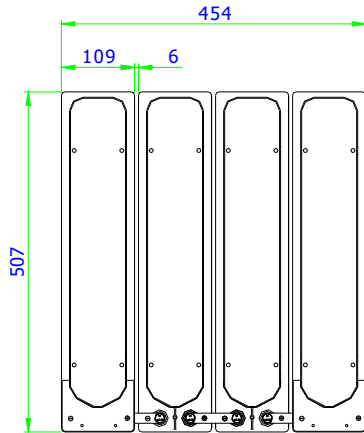

12-90&95 Front Access
Battery Height: 227mm

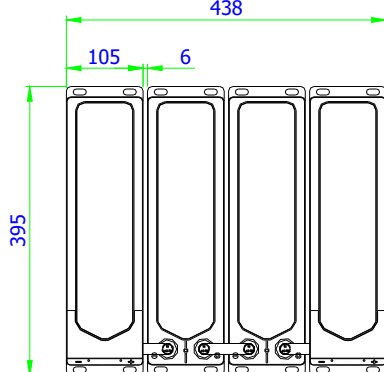

12-95-2 Front Access
Battery Height: 257mm

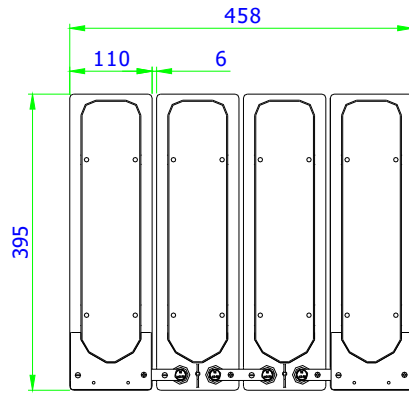

12-100 Front Access
Battery Height: 285mm

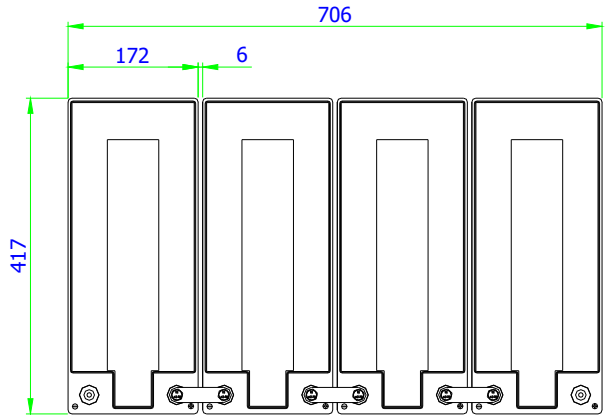

12-125 Front Access
Battery Height: 240mm

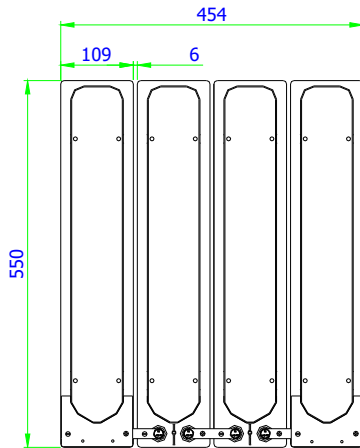

12-150 Front Access
Battery Height: 285mm

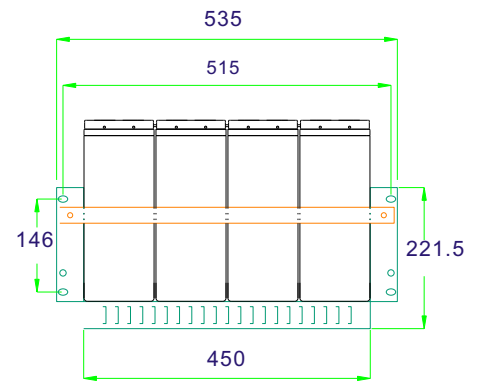

300mm Deep ETSI tray

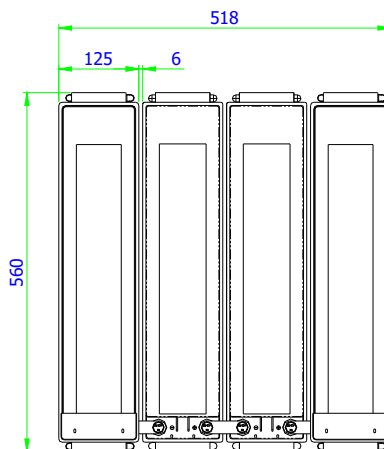

12-170&180 Front Access
Battery Height: 320mm

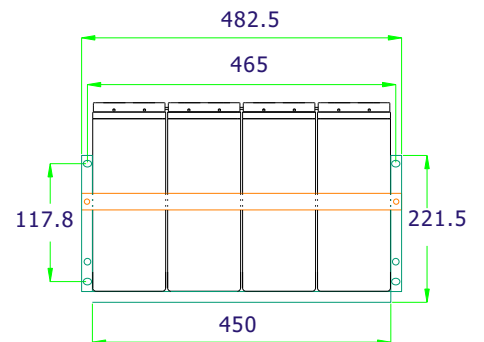

300mm deep 19 inch tray

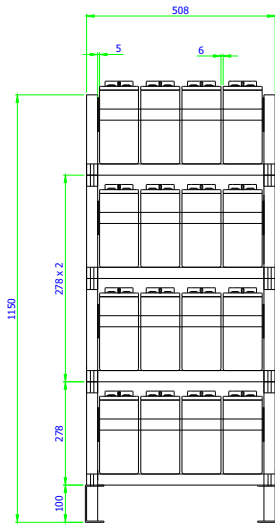

Front View

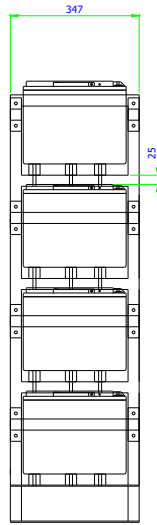

Side View

16 x 12V50FA&55FA Rack

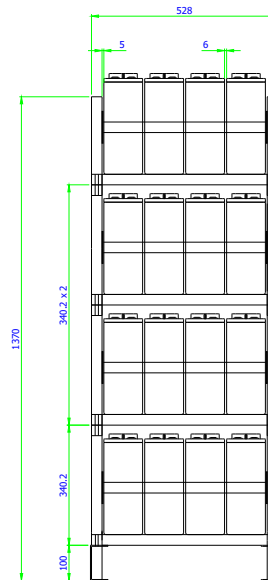

Front View

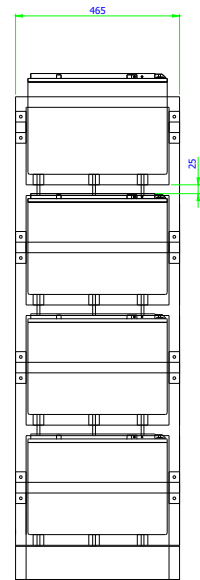

Side View

16 x 12V100FA Rack

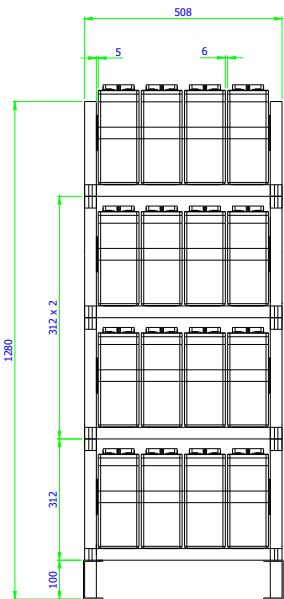

Front View

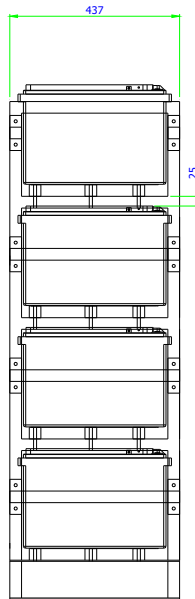

Side View

16 x 12V95FA-2 Rack

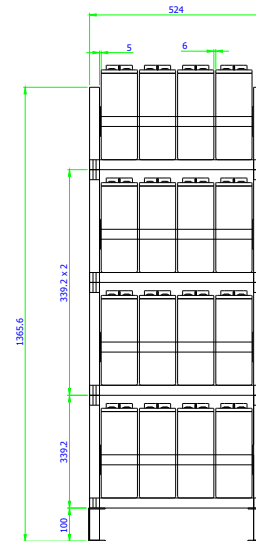

Front View

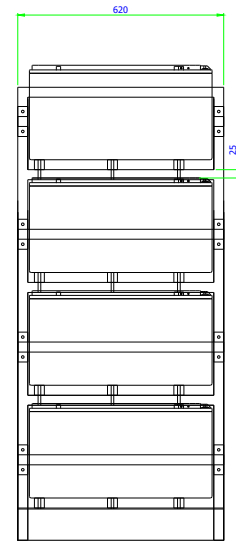

Side View

16 x 12V150FA Rack

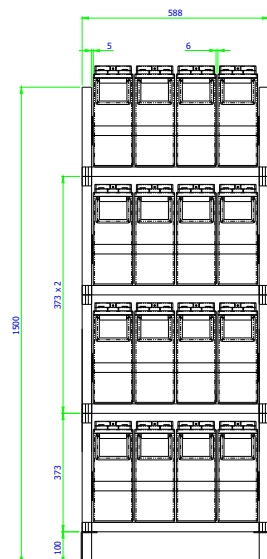

Front View

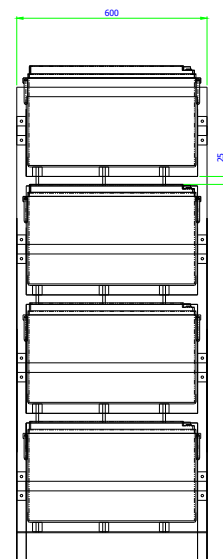

Side View

16 x 12V170FA&180FA Rack

As can be seen from the rack diagrams, the Haze Front Access range are compatible with ETSI and standard 19" and 23" rack configurations, only the HZB12 125FA can not be used in the standard ETSI and 19" formats. 300mm or 600mm deep trays can be utilised.

Other racking configurations can be tailored to meet the customers needs for a new installation or indeed to replace an existing arrangement utilising the same footprint.

The Front Access design allows racking clearances to be reduced whilst still allowing easy access for intercell connection and terminal inspection, all resulting in time and cost savings.

With reduced space requirements the designer has the option of smaller cabinets or more power from the same footprint.



Haze Battery Company Ltd

Product Range

4, 6 & 12 Volt AGM 1.3 to 230AH
6 & 12 Volt Gel 7.5 to 230AH
12 Volt Front Access AGM
12 Volt Front Access Gel
2 Volt AGM & Gel 50 to 3850AH
EV Gel
EV AGM
Marine Gel
Solar
OPzV
OPzS

Website: www.hazebattery.com
E mail sales@hazebattery.com

061112

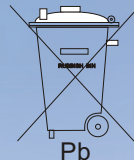

Haze Battery Company keenly encourages environmental awareness; PLEASE follow guidelines for the recycling /disposal of lead.